

NL Installatievoorschrift
Inductiekookplaten

GB Installation instructions
Induction hobs

DE Installationsanleitung
Induktionskochfeld

FR Instructions d'installation
BE Plaque de cuisson induction



Dit toestel mag alleen door een erkend installateur worden aangesloten. Lees de veiligheidsvoorschriften.
The fitting of the appliance should only be carried out by a registered and qualified installer. Please read the safety regulations.
Cet appareil ne peut être installé que par un technicien gazier agréé. Lisez les instructions de sécurité.
Dieses Gerät darf nur von einem anerkannten Installateur angeschlossen werden! Bitte lesen Sie die Sicherheitsbestimmungen.

**Vorbereidingen voor montage/Preparations for installation
Préparation avant installation/Vorbereitung der Montage**

Gebuurkte pictogrammen/Pictograms used
Pictogrammes utilisés/Verwendete Piktogramme



Belangrijk om te weten/Important information
Important à savoir/Wichtig zu wissen



Elektrische aansluiting/Electrical connection
Branchement électrique/Elektrische anschluss

Vrije ruimte rondom toestel
Free space around appliance
Espace libre autour de l'appareil
Freier Raum rundum das Gerät

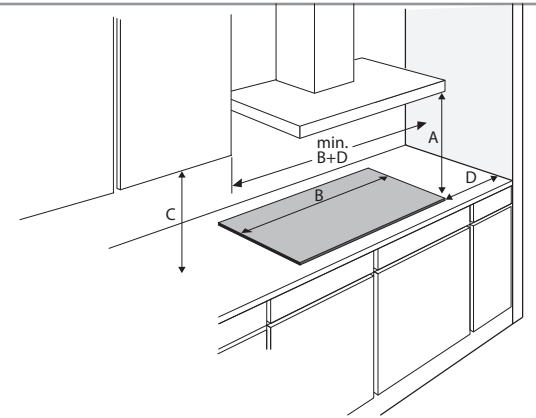

A (mm) C (mm) D (mm)
min. 650 min. 450 min. 50



Dit toestel moet altijd geaard zijn.
This appliance must be earthed.
Cet appareil doit être mis à la terre.
Dieses Gerät muß jederzeit geerdet sein.

De elektrische aansluiting moet voldoen aan de nationale en lokale voorschriften.
The electrical connection must comply with national and local regulations.
Le branchement électrique doit satisfaire aux prescriptions nationales et locales.
Der elektrische Anschluß muß den nationalen und kommunalen Vorschriften entsprechen.

Aansluitwaarden/Connected load/Charge connectée/Anschlussleistung

	L1 (W)	L2 (W)	L3 (W)	Total load (W)
KIS260ZT	3500			3500
KIS560ZT	3500			3500
KIS577ZT	3500			3500

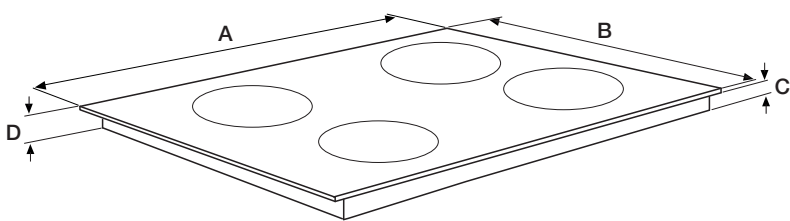

	A (mm)	B (mm)	C (mm)	D (mm)
KIS260ZT	590	520	56	60
KIS560ZT	590	520	56	60
KIS577ZT	770	520	56	60

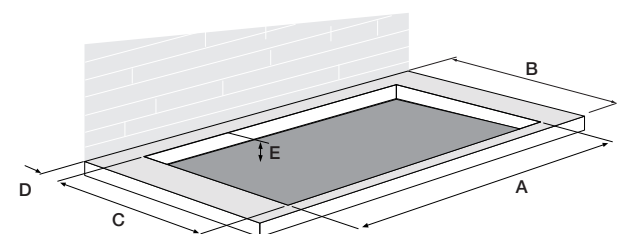

	A (mm)	B (mm)	C (mm)	D (>mm)	E (>mm)
KIS260ZT	560	600	490	50	64
KIS560ZT	560	600	490	50	64
KIS577ZT	750	600	490	50	64

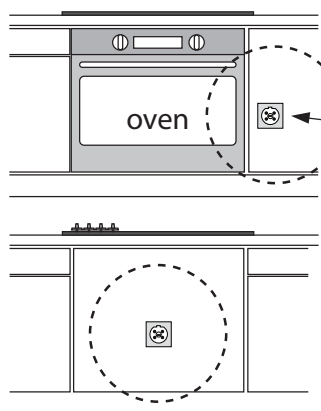

Bereikbaarheid!
Accessibility!
Accessibilité!
Zugänglichkeit!

Afdichtband plaatsen/Placing sealing tape
Placement de la bande d'étanchéité/Abdichtband anbringen

aanrechtblad
 Worktop
 Plan de travail
 Arbeitsplatte

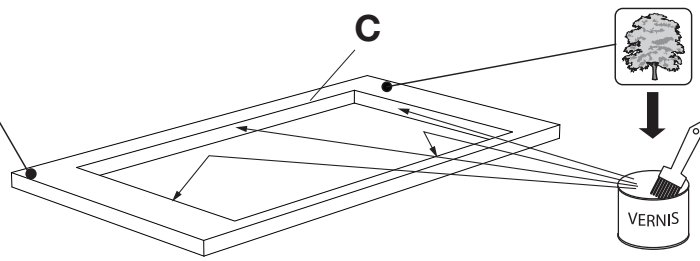

Elektrische aansluiting/Electrical connection
Branchement électrique/Elektrische anschluss

1 1N 220-240V 50/60Hz - 1x 32A

1 fase - 1 nul / 1 phase - 1 neutral

1 Phase - 1 Nullanschluss / 1 phase et 1 neutre

Aerdoorsnede
 Cross sectional area
 Fil diamètre
 Aderquerschnitt

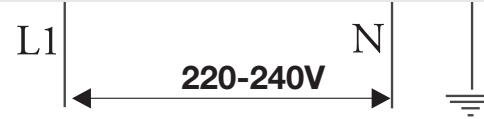

Beluchting/Ventilation/Belüftung/

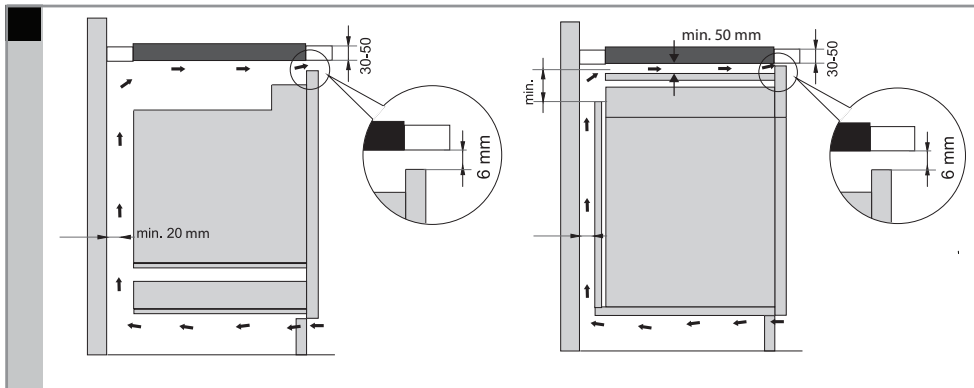
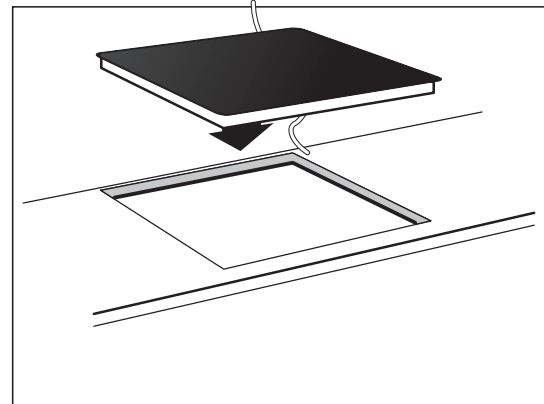
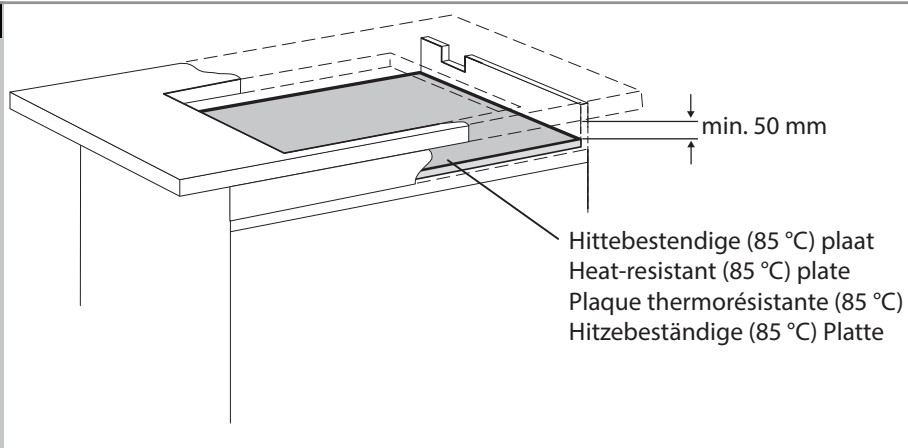

806943