

NL Installatievoorschrift
BE Inductiekookplaten

GB Installation instructions
Induction hobs

DE Installationsanleitung
Induktionskochfeld

FR Instructions d'installation
BE Plaque de cuisson induction



Dit toestel mag alleen door een erkend installateur worden aangesloten. Lees de veiligheidsvoorschriften.
The fitting of the appliance should only be carried out by a registered and qualified installer. Please read the safety regulations.
Cet appareil ne peut être installé que par un technicien gazier agréé. Lisez les instructions de sécurité.
Dieses Gerät darf nur von einem anerkannten Installateur angeschlossen werden! Bitte lesen Sie die Sicherheitsbestimmungen.

**Vorbereidingen voor montage/Preparations for installation
Préparation avant installation/Vorbereitung der Montage**

Gebruikte pictogrammen/Pictograms used
Pictogrammes utilisés/Verwendete Piktogramme

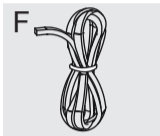

Belangrijk om te weten/Important information
Important à savoir/Wichtig zu wissen



Elektrische aansluiting/Electrical connection
Branchement électrique/Elektrische anschluss

Vrije ruimte rondom toestel
Free space around appliance
Espace libre autour de l'appareil
Freier Raum rundum das Gerät

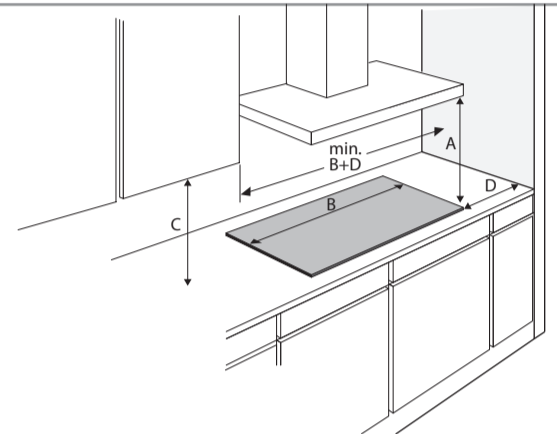

A (mm) C (mm) D (mm)
min. 650 min. 450 min. 50



Dit toestel moet altijd geaard zijn.
This appliance must be earthed.
Cet appareil doit être mis à la terre.
Dieses Gerät muß jederzeit geerdet sein.

De elektrische aansluiting moet voldoen aan de nationale en lokale voorschriften.
The electrical connection must comply with national and local regulations.
Le branchement électrique doit satisfaire aux prescriptions nationales et locales.
Der elektrische Anschluß muß den nationalen und kommunalen Vorschriften entsprechen.

Aansluitwaarden/Connected load/Charge connectée/Anschlussleistung

	L1 (W)	L2 (W)	L3 (W)	Total load (W)
KI160/KI260ZT	3700	3700		7400
KI278ZT/KIF260ZT	3700	3700		7400
KI290ZT	3650	3500	3650	10800

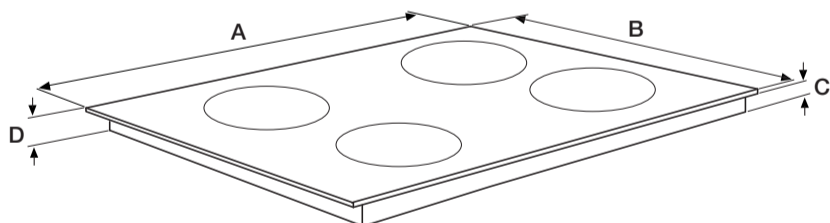

	A (mm)	B (mm)	C (mm)	D (mm)
KI160ZT	590	520	56	60
KI260ZT	590	520	56	60
KI278ZT	780	520	56	60
KIF260ZT	590	520	56	60
KI290ZT	890	520	56	60

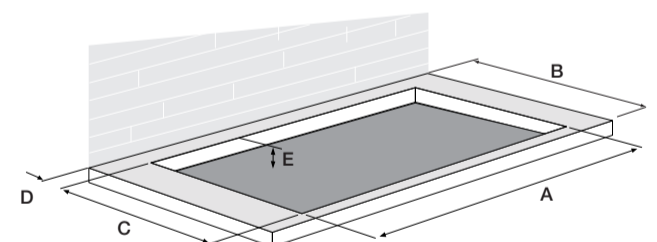

	A (mm)	B (mm)	C (mm)	D (>mm)	E (>mm)
KI160ZT/KI260ZT	560	600	490	50	64
KI278ZT	750	600	490	50	64
KIF260ZT	560	600	490	50	64
KI290ZT	860	600	490	50	64

**Afdichtband plaatsen/Placing sealing tape
Placement de la bande d'étanchéité/Abdichtband anbringen**

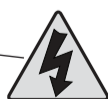
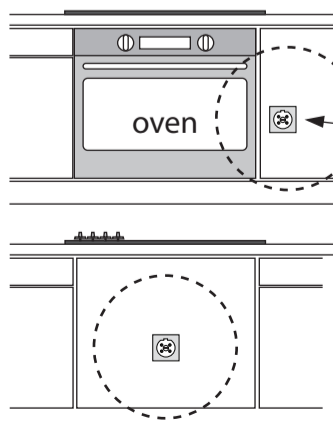

Bereikbaarheid!
Accessibility!
Accessibilité!
Zugänglichkeit!

Aanrechtblad
Worktop
Plan de travail
Arbeitsplatte

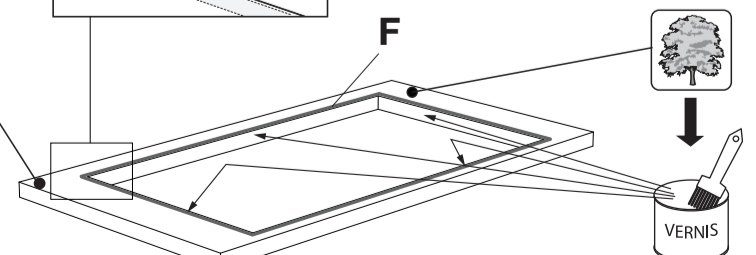
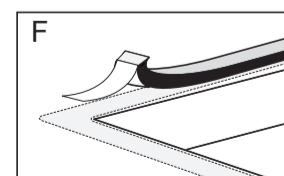



**Elektrische aansluiting/Electrical connection
Branchement électrique/Elektrische anschluss**

2N 380-415V 50/60Hz - 2x 16A ⇐
2 fase - 1 nul / 2 phases - 1 neutral
2 Phasen - 1 Nullanschluss / 2 phases et 1 neutre

Aderdoorsnede
Cross sectional area
Fil diamètre
Aderquerschnitt **4x1,5 mm²**

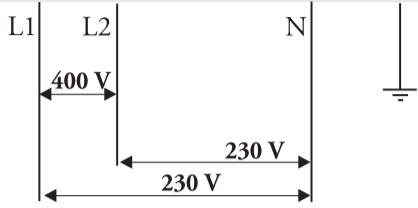

2-2N 230V 50Hz - 2x 16A ⇐
2 fase - 2 nullen / 2 phases - 2 neutral
2 Phasen - 2 Nullanschlüsse / 2 phases et 2 neutres

Aderdoorsnede
Cross sectional area
Fil diamètre
Aderquerschnitt **5x1,5 mm²**

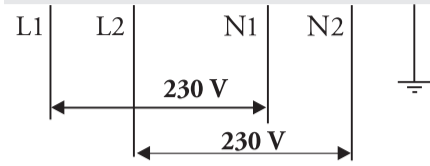

Only NL / Alleen NL



De 2 fasen van de kookgroep-automaat moeten door 1 aardlekschakelaar gevoed worden. Het is niet toegestaan om L1/N1 via een andere aardlekschakelaar te laten lopen dan L2/N2

1 1N 220-240V 50/60Hz - 1x 32A ⇐
1 fase - 1 nul / 1 phase - 1 neutral
1 Phase - 1 Nullanschluss / 1 phase et 1 neutre

Aderdoorsnede
Cross sectional area
Fil diamètre
Aderquerschnitt **3x4 mm²**



KI290ZT ONLY

3N 380-415V 50/60Hz - 3x 16A ⇐
3 fase - 1 nul / 3 phases - 1 neutral
3 Phasen - 1 Nullanschluss / 3 phases et un neutre

Aderdoorsnede
Cross sectional area
Fil diamètre
Aderquerschnitt **5x1,5 mm²**

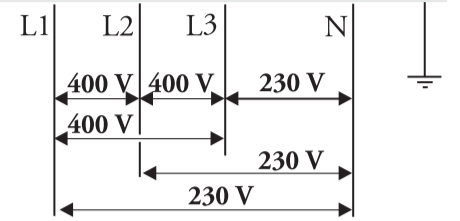

Raadpleeg de aansluitschema's op de achterzijde van het toestel/Maak de nodige doorverbindingen op het aansluitblok!
Consult the wiring diagrams on the back of the appliance/Make the required connections on the connecting block!
Consultez les schémas de raccordement situés derrière l'appareil/Effectuez les connexions nécessaires sur le bloc de raccordement !
Beachten Sie das Anschlussdiagramm auf der Rückseite des Geräts/Stellen Sie die erforderlichen Anschlussverbindungen am Anschlussblock her!

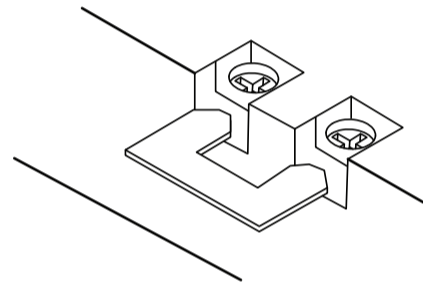
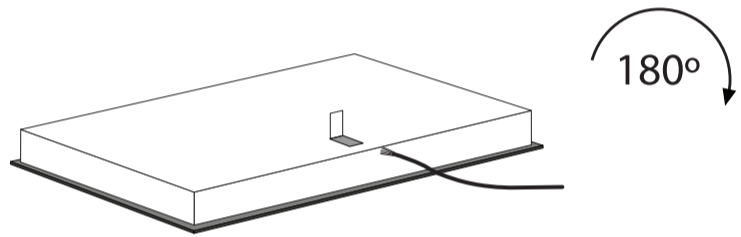

Beluchting/Ventilation/Belüftung/

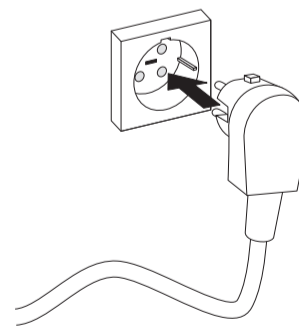
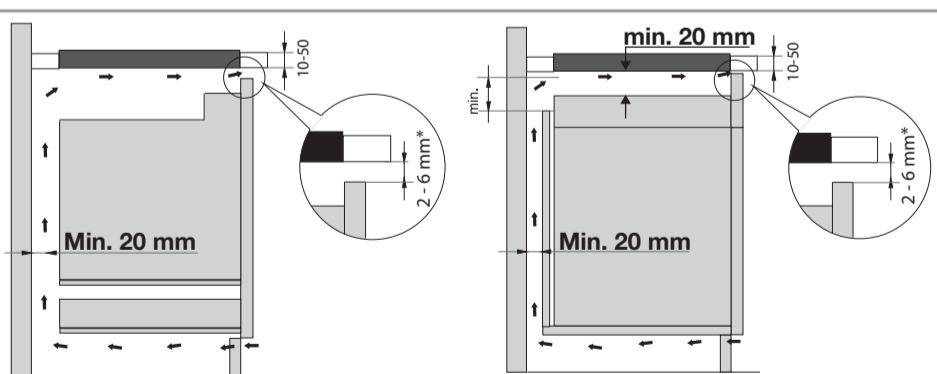
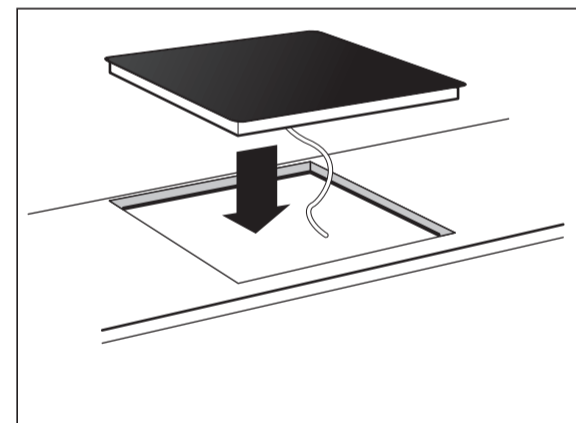
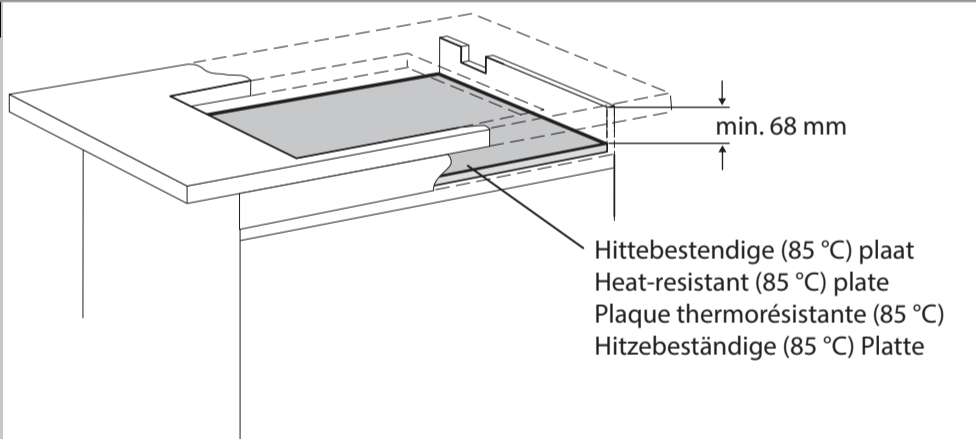

Op onze website kunt u de meest recente versie van het installatievoorschrift vinden.
You can find the most recent version of the installation instructions on our website.
Die neueste Version der Installationsanleitung finden Sie auf unserer Website.
Vous pouvez trouver la version la plus récente des instructions d'installation sur notre site Web.

