

NL Installatievoorschrift
BE Inductiekookplaten

GB Installation instructions
 Induction hobs

DE Installationsanleitung
 Induktionskochfeld

FR Instructions d'installation
BE Plaque de cuisson induction



Dit toestel mag alleen door een erkend installateur worden aangesloten. Lees de veiligheidsvoorschriften.
 The fitting of the appliance should only be carried out by a registered and qualified installer. Please read the safety regulations.
 Cet appareil ne peut être installé que par un technicien gazier agréé. Lisez les instructions de sécurité.
 Dieses Gerät darf nur von einem anerkannten Installateur angeschlossen werden! Bitte lesen Sie die Sicherheitsbestimmungen.

Vorbereidingen voor montage/Preparations for installation
Préparation avant installation/Vorbereitung der Montage

Gebruikte pictogrammen/Pictograms used
 Pictogrammes utilisés/Verwendete Piktogramme

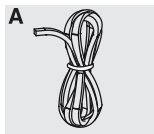

Belangrijk om te weten/Important information
 Important à savoir/Wichtig zu wissen



Elektrische aansluiting/Electrical connection
 Branchement électrique/Elektrische anschluss

Vrije ruimte rondom toestel
 Free space around appliance
 Espace libre autour de l'appareil
 Freier Raum rundum das Gerät

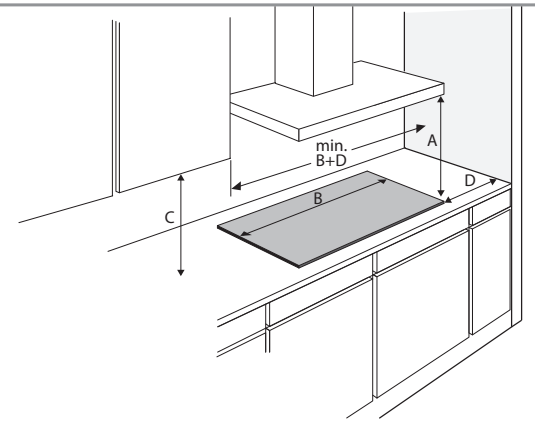

A (mm) C (mm) D (mm)
 min. 650 min. 450 min. 40



Dit toestel moet altijd geaard zijn.
 This appliance must be earthed.
 Cet appareil doit être mis à la terre.
 Dieses Gerät muß jederzeit geerdet sein.

De elektrische aansluiting moet voldoen aan de nationale en lokale voorschriften.
 The electrical connection must comply with national and local regulations.
 Le branchement électrique doit satisfaire aux prescriptions nationales et locales.
 Der elektrische Anschluß muß den nationalen und kommunalen Vorschriften entsprechen.

Aansluitwaarden/Connected load/Charge connectée/Anschlussleistung

	L1 (W)	L2 (W)	L3 (W)	Total load (W)
KC130ZT	3000			3000
KC160/KC260ZT	3500	3000		6500
KC360ZT/RVS	3400	2900		6300
KC380ZT	3500	3600		7100

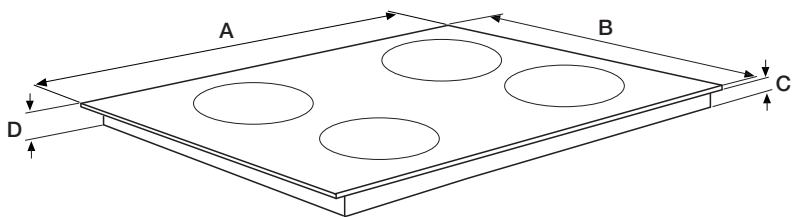

	A (mm)	B (mm)	C (mm)	D (mm)
KC130ZT	300	520	58	62
KC160ZT	595	520	58	62
KC260ZT	595	520	58	62
KC360ZT	595	520	58	62
KC360RVS	600	525	58	62
KC380ZT	795	520	50	54

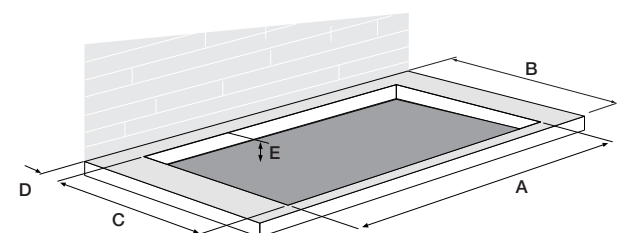

	A (mm)	B (mm)	C (mm)	D (>mm)	E (>mm)
KC130ZT	285	600	490	40	80
KC160ZT	560	600	490	40	80
KC260ZT	560	600	490	40	80
KC360ZT/RVS	560	600	490	40	80
KC380ZT	750	600	490	40	80

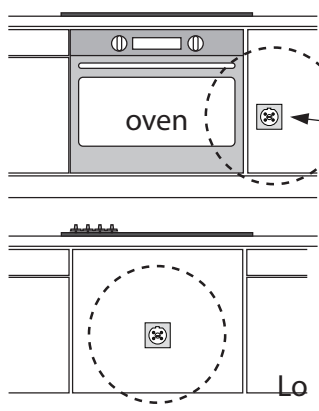

Bereikbaarheid!
 Accessibility!
 Accessibilité!
 Zugänglichkeit!

Afdichtband plaatsen/Placing sealing tape
Placement de la bande d'étanchéité/Abdichtband anbringen

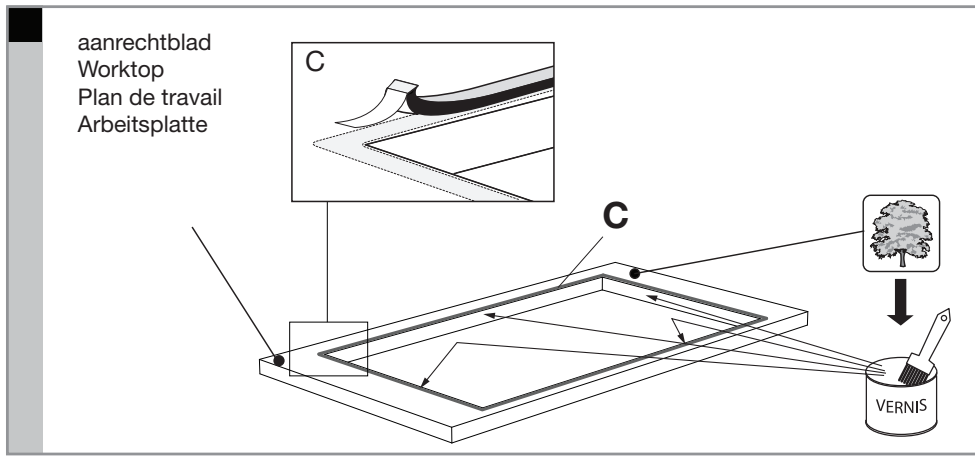

Elektrische aansluiting/Electrical connection
Branchement électrique/Elektrische anschluss

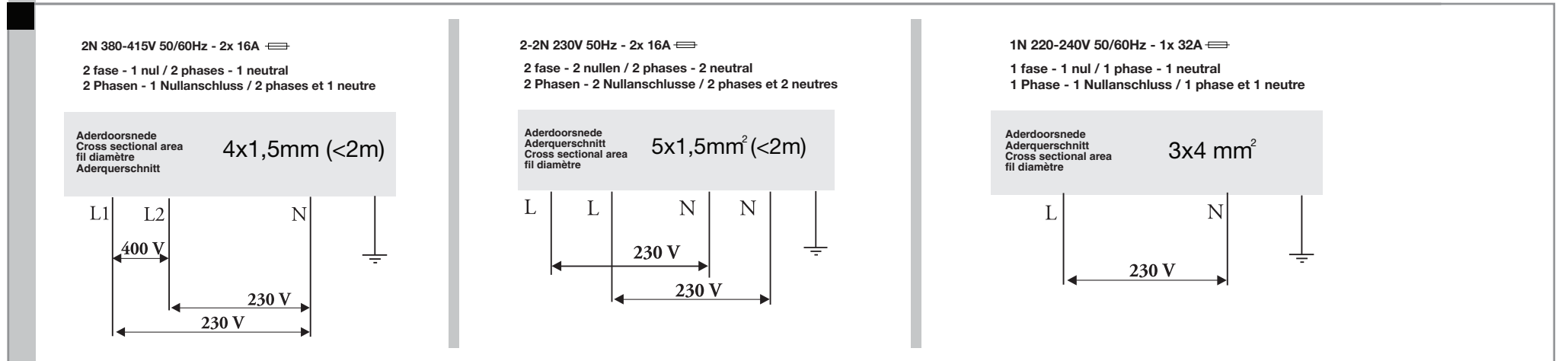

Raadpleeg de aansluitschema's op de achterzijde van het toestel/Maak de nodige doorverbindingen op het aansluitblok!
Consult the wiring diagrams on the back of the appliance/Make the required connections on the connecting block.
Consultez les schémas de raccordement situés derrière l'appareil/Effectuez les connexions nécessaires sur le bloc de raccordement !
Beachten Sie das Anschlussdiagramm auf der Rückseite des Geräts/Stellen Sie die erforderlichen Anschlussverbindungen am Anschlussblock her!

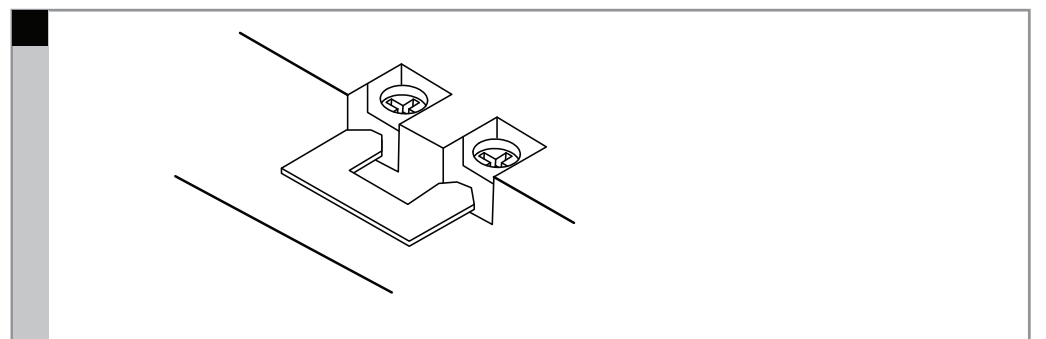
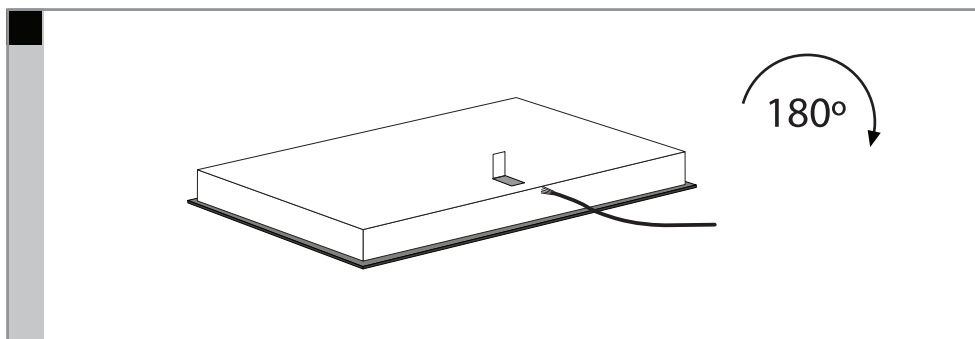

Beluchting/Ventilation/Belüftung/

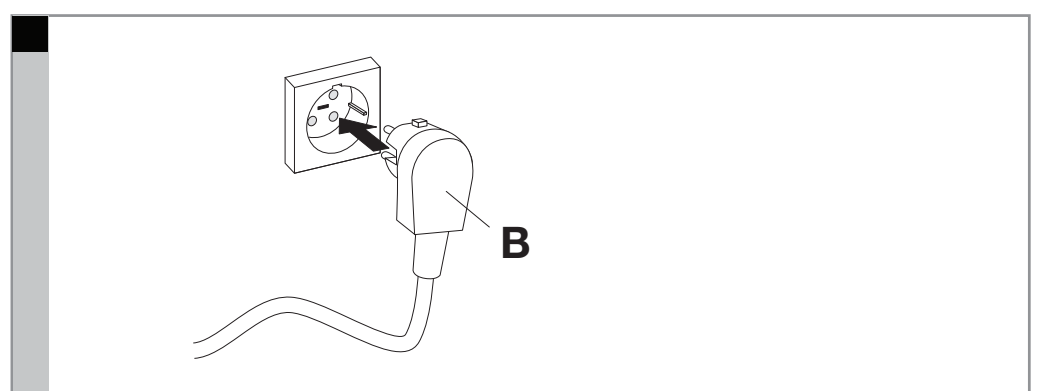
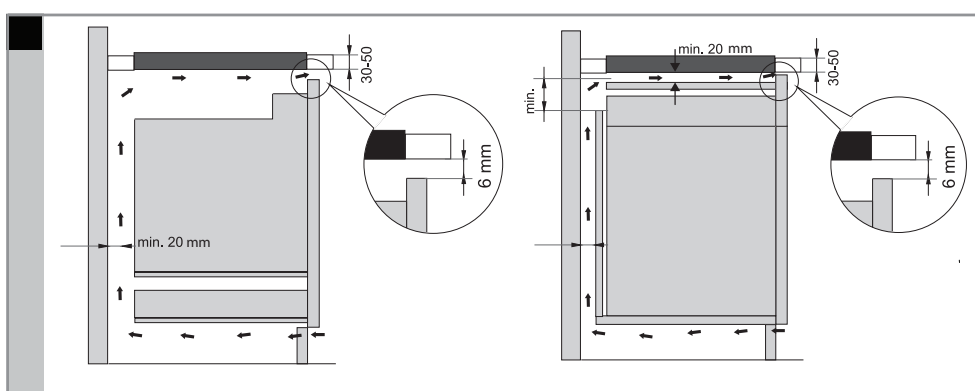
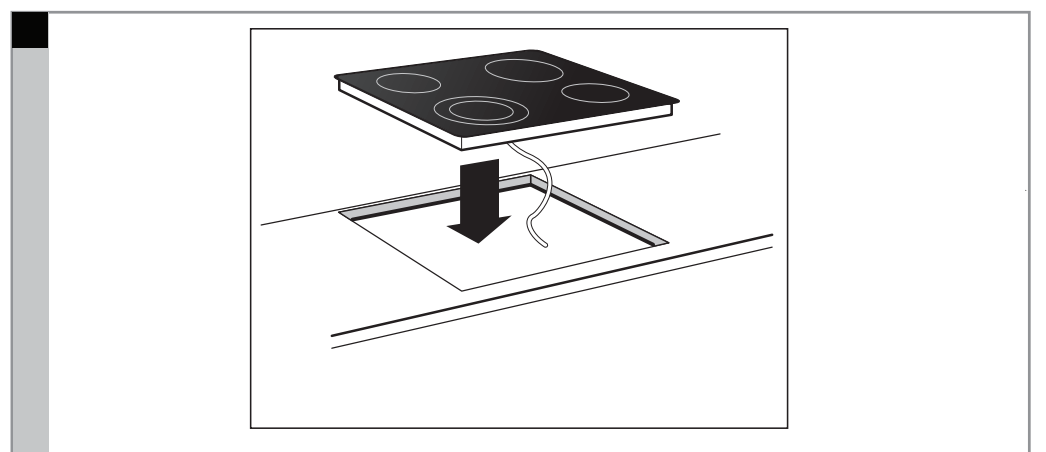
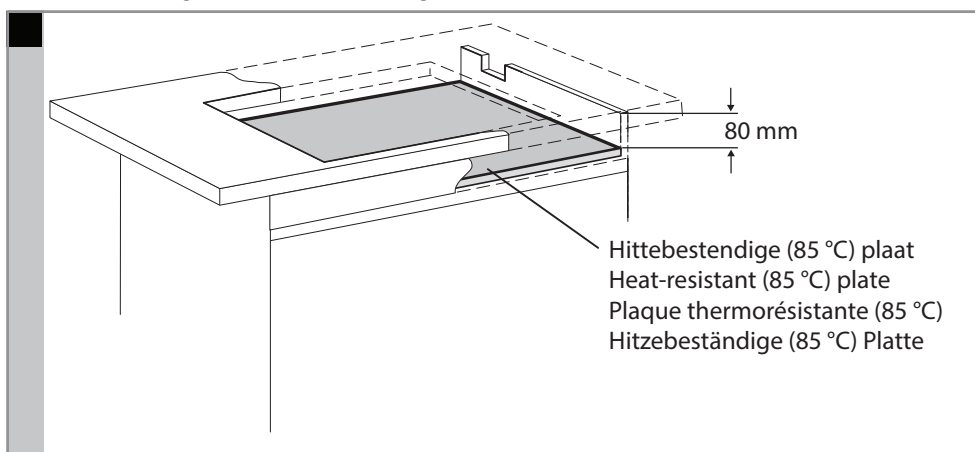

713636