

NL Installatievoorschrift

Inbouweenheid

DE Installationsanleitung

Einbaueinheit

DK Installation

Indbygget enhed

SE Monteringsanvisningar

Inbygggnadsenhet

RU Руководство по монтажу

Встроенное устройство

GB Installation instructions

Built-in units

IT Istruzioni di installazione

Unità integrata

NO Installasjonsanvisninger

Innebygget enhet

FI Asennusohjeet

Keittokaisikkö

KZ Орнату нұсқаулары

Кірістірілген құрылғы

FR Instructions d'installation

Unité encastrée



Dit toestel mag alleen door een erkend installateur worden aangesloten. Lees de veiligheidsvoorschriften.

The fitting of the appliance should only be carried out by a registered Corgi qualified installer. Please read the safety regulations.

Cet appareil ne peut être installé que par un technicien gazier agréé. Lisez les instructions de sécurité.

Dieses Gerät darf nur von einem anerkannten Installateur angeschlossen werden! Bitte lesen Sie die Sicherheitsbestimmungen.

Il montaggio dell'apparecchio deve essere effettuato da un installatore Corgi registrato qualificato. Si prega di leggere le norme di sicurezza.

Montering af apparatet bør kun udføres af en autoriseret installatør. Læs venligst disse sikkerhedsregler.

Montering av apparatet må kun utføres av en sertifisert installatør. Vennligst les sikkerhetsforskriftene.

Montering av apparaten ska endast utföras av en certifierad installatör. Läs igenom säkerhetsföreskrifterna.

Laitteen asennuksen saa suorittaa vain valtuutettu Corgi-asentaja. Lue turvallisuusmääräykset.

Монтаж прибора должен выполнять квалифицированный специалист. Ознакомьтесь с правилами техники безопасности.

Құрылғыны орнату тек тіркелген Corgi газ орнатушысы арқылы жүргізілуі тиіс. Қауіпсіздік ережелерін оқып шығыңыз.

Vorbereidingen voor montage/Preparations for installation/Préparation avant installation/Vorbereitung der Montage / Preparazione dell'installazione/Forberedelser før montagen
Forberedelser for montering / Förberedelser för montering/Asennuksen esivalmistelu/Подготовка к монтажу/Орнату дайындықтары



Controleer of de netspanning overeenkomt met wat er staat vermeld op het typeplaatje in de afzuigkap. / Check that the mains voltage corresponds to that indicated on the rating plate fixed inside the hood.

Vérifiez que le voltage principal correspond à celui indiqué sur la plaque signalétique fixée dans la hotte. / Überprüfen Sie, dass die Netzspannung mit der auf dem Typenschild, das innen an der Abzugshaube angebracht ist,

übereinstimmt. / Controllare che la tensione di rete corrisponda a quella indicata sulla targhetta fissata all'interno della cappa. / Kontrollere, at netspændingen stemmer overens med, hvad der står på mærkepladen, som

sidder på indersiden af emhætten. / Kontrollere at netspændingen tilsvare det som angis på typeskiltet på innsiden av avtrekksviften. / Kontrollera att nätspänningen motsvarar den som anges på märkplåten inuti huvan.

Varmista, että käytettävissä oleva verkkojännite vastaa liesituulettimen sisällä olevan arvokilven tietoja. / Убедитесь, что напряжение сети соответствует указанному на паспортной табличке, закрепленной

внутри вытяжки. / елілік кернеу корпус ішіне бекітілген техникалық деректер кестесінде көрсетілген кернеуге сәйкес екендігін тексеріңіз.

Gebuikte pictogrammen/Pictograms used/
Pictogrammes utilisés/Verwendete Piktogramme
Simboli utilizzati/Anvendte piktogrammer/Piktogrammer som brukes
Använda diagram/Käytetyt kuvakkeet/Используемые пиктограммы/
Қолданылған пиктограмма лар



Belangrijke informatie/Important information/Important à savoir

Wichtig zu wissen/Informazioni importanti/Viktigt at vide

Viktig informasjon/Viktig information/Tärkeää tietoa

Важная информация/Маңызды ақпарат



Elektrische aansluiting/Electrical connection/Branchement électrique

Elektrische anschluss/Collegamento elettrico

Elektrisk tilslutning/Elektrisk tilkobling

Elektrisk anslutning/Sähköliitäntä

Подключение электроэнергии/Электрлік қосылым



Dit apparaat moet geaard zijn/This appliance must be earthed/
Cet appareil doit être mis à la terre/Dieses Gerät muß jederzeit geerdet sein/
Questo elettrodomestico necessita di essere messo a terra/Apparaten måste jordas/
Dette apparatet må alltid være jordet/Dette apparat skal alltid jordes/
Tämä laite pitää maadoittaa./Данный прибор должен быть заземлен/
Бұл құрылғы жерге тұйықталуы керек.

De elektrische aansluiting moet voldoen aan de nationale en lokale voorschriften.

The electrical connection must comply with national and local regulations.

Le branchement électrique doit satisfaire aux prescriptions nationales et locales.

Der elektrische Anschluß muß den nationalen und kommunalen Vorschriften entsprechen.

Il collegamento elettrico deve essere conforme alle normative nazionali e locali.

Den elektriske tilslutning skal overholde nationale og lokale bestemmelser.

De elektriske koblingene må være i henhold til nasjonale og lokale reguleringer.

Anslutningen måste stämma överens med nationella och lokala bestämmelser.

Sähköliitännän on oltava kansallisten ja paikallisten määräysten mukainen./Подключение

к электрической сети должно соответствовать действующему законодательству

Электрлік қосылым ұлттық және жергілікті заңдарға сәйкес жасалуы тиіс.

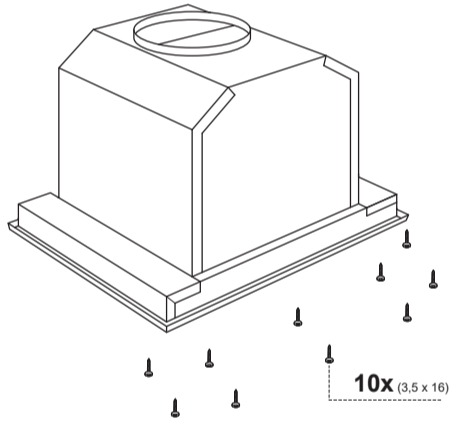
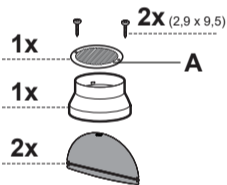

Max. 100 cm

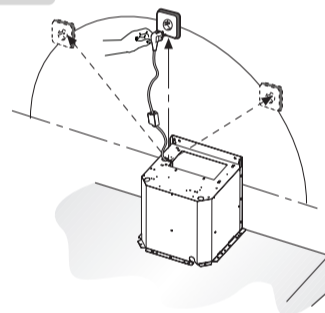

D= min. 650 mm
D= min. 550 mm

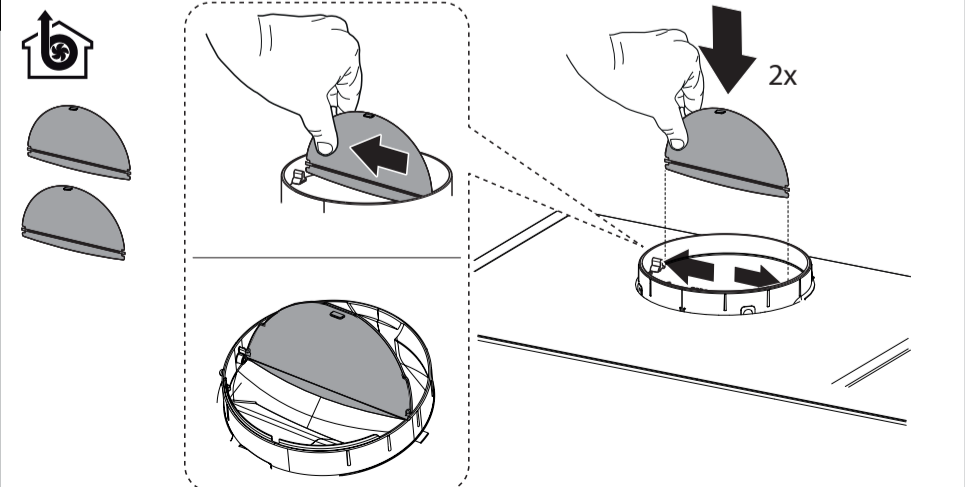
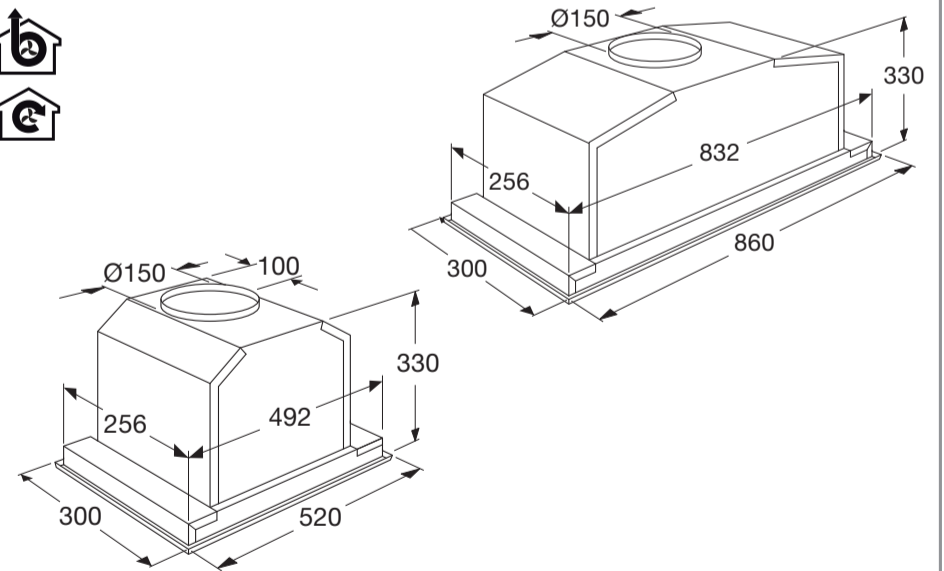
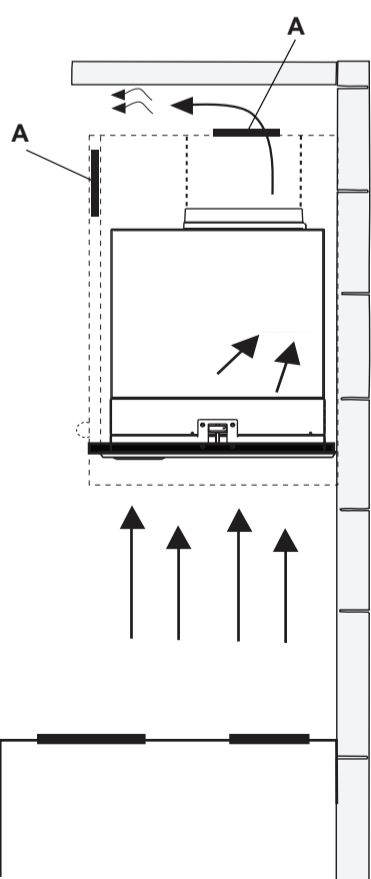
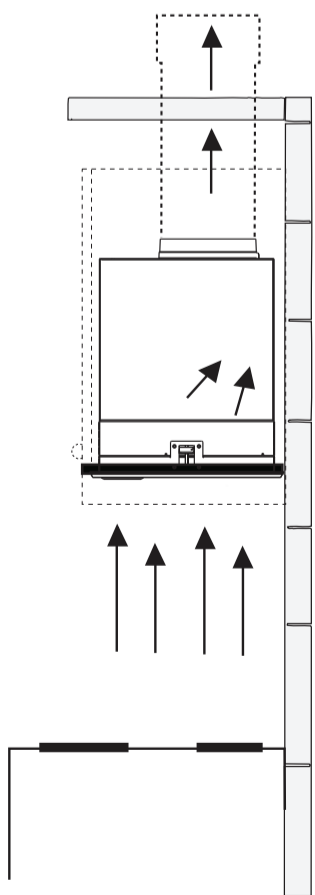

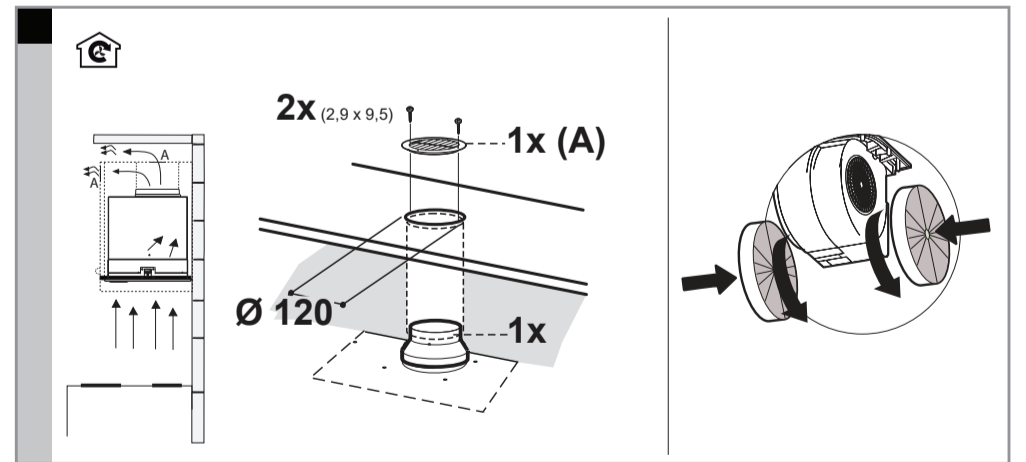
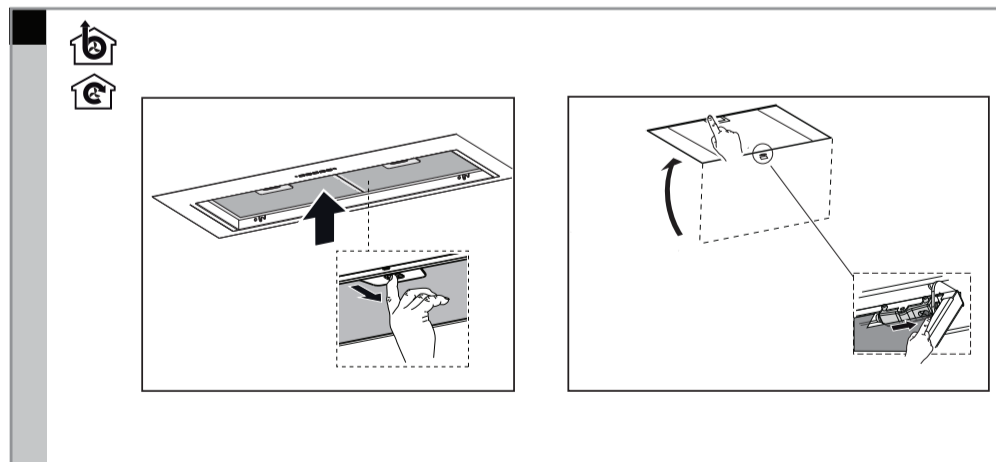
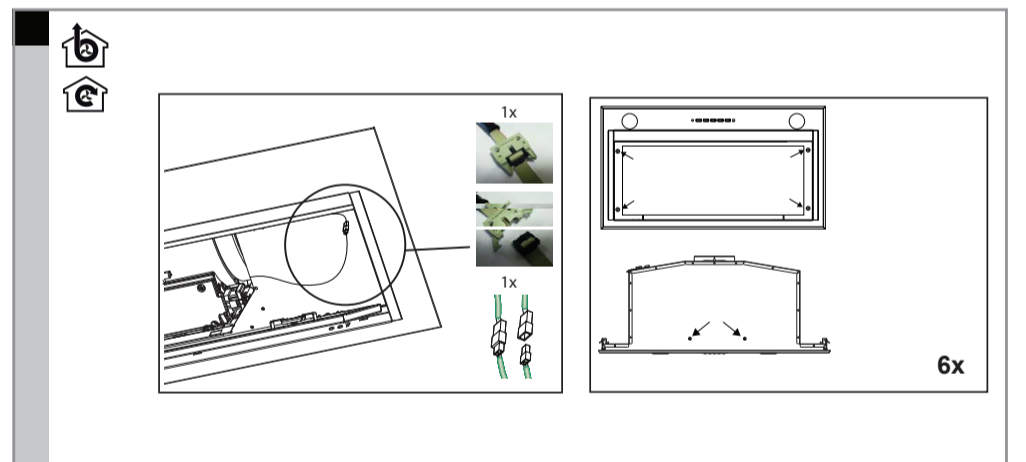
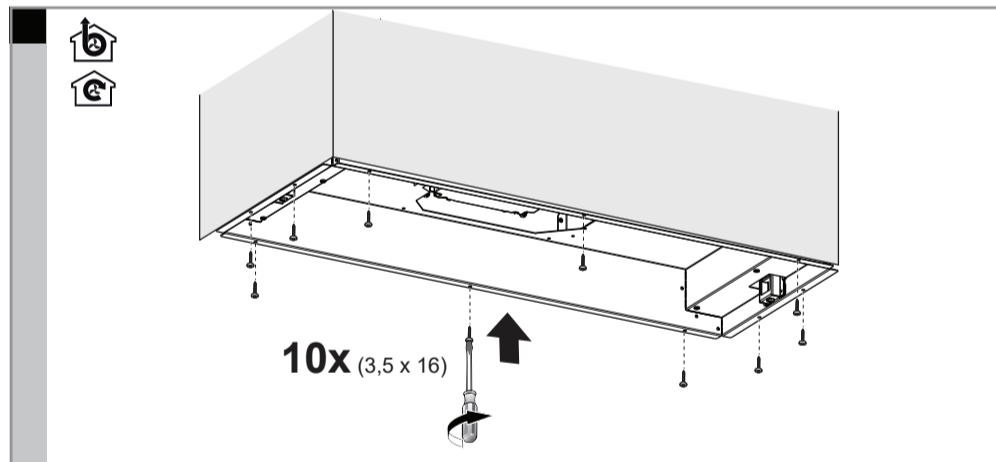
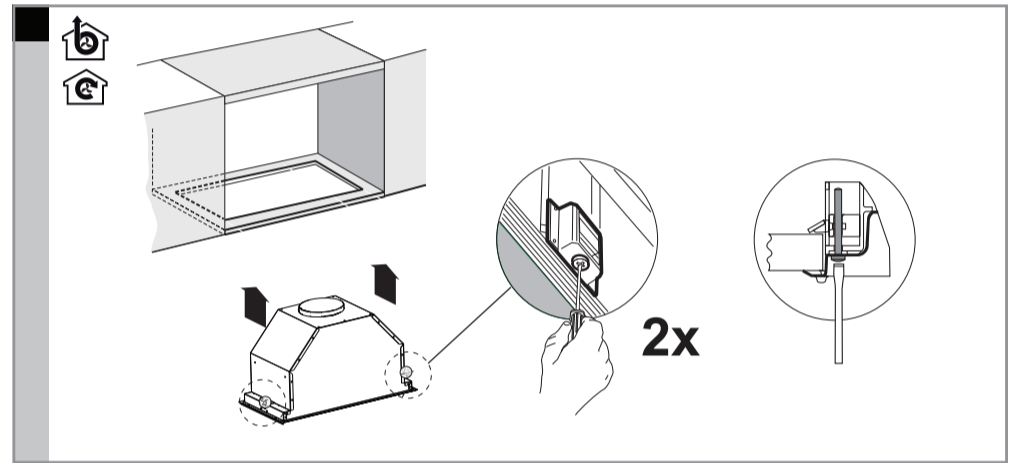
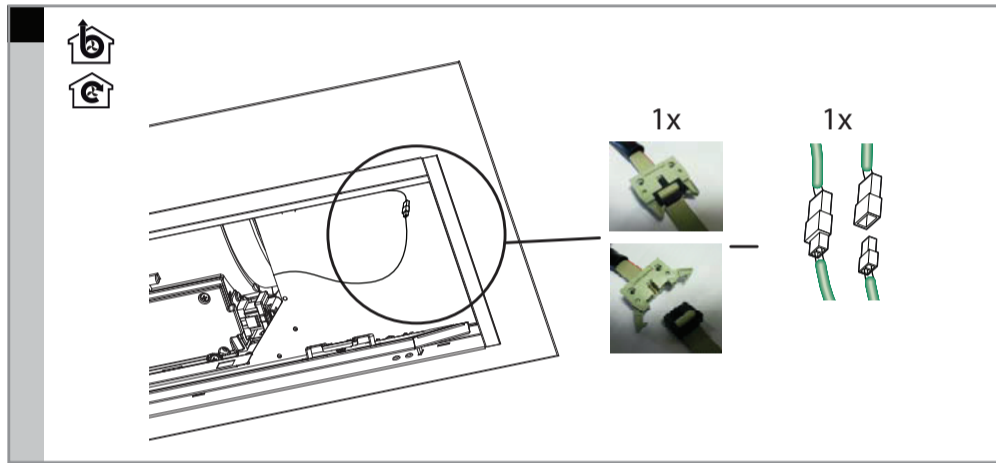
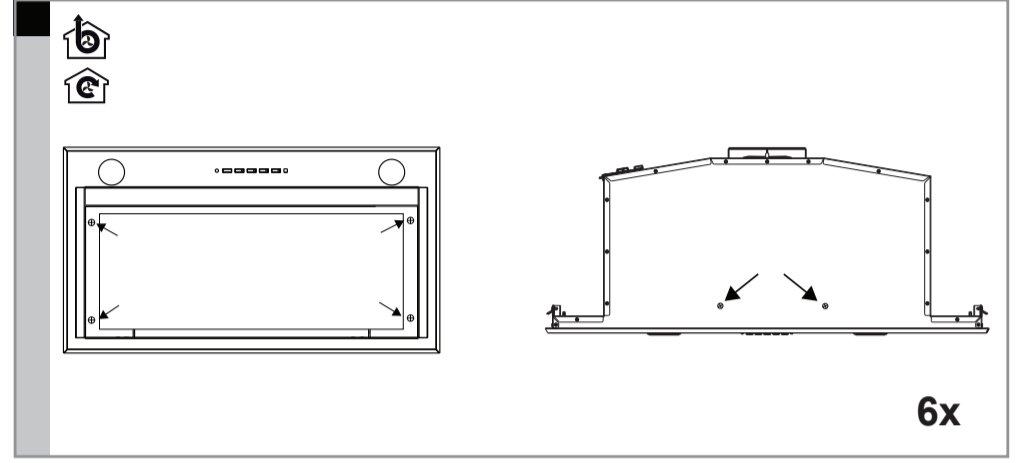
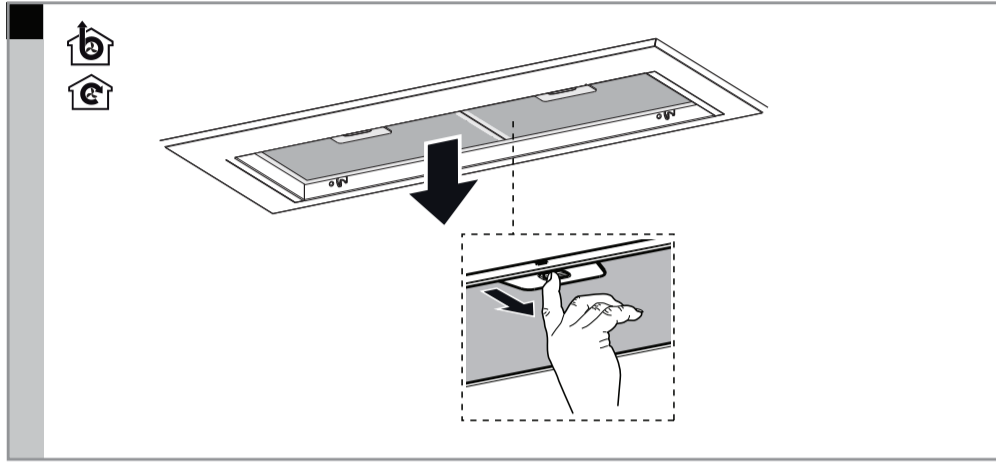
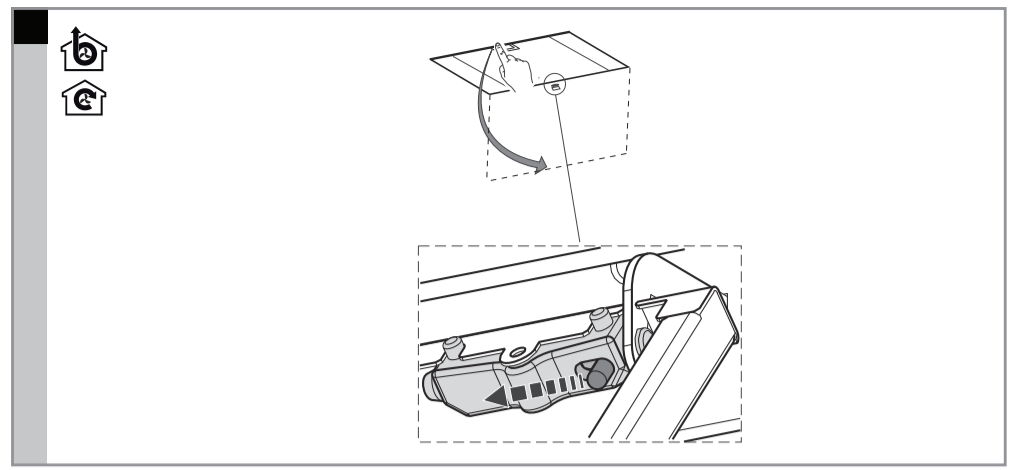
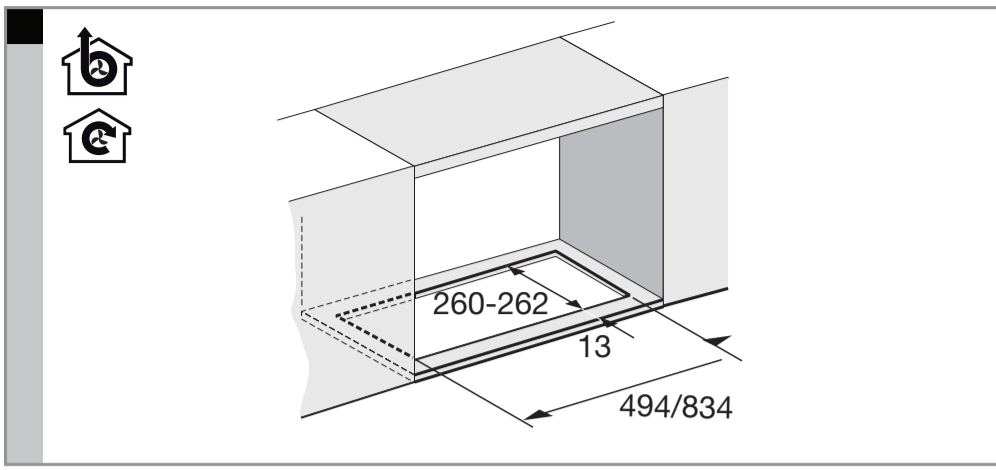

548691