

NL Installatievoorschrift
BE Inductiekookplaten

GB Installation instructions
Induction hobs

DE Installationsanleitung
Induktionskochfeld

FR Instructions d'installation
BE Plaque de cuisson induction



Dit toestel mag alleen door een erkend installateur worden aangesloten. Lees de veiligheidsvoorschriften.
The fitting of the appliance should only be carried out by a registered and qualified installer. Please read the safety regulations.
Cet appareil ne peut être installé que par un technicien gazier agréé. Lisez les instructions de sécurité.
Dieses Gerät darf nur von einem anerkannten Installateur angeschlossen werden! Bitte lesen Sie die Sicherheitsbestimmungen.

Vorbereidingen voor montage/Preparations for installation
Préparation avant installation/Vorbereitung der Montage

Gebuchte pictogrammen/Pictograms used
Pictogrammes utilisés/Verwendete Piktogramme

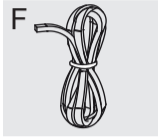

Belangrijk om te weten/Important information
Important à savoir/Wichtig zu wissen



Elektrische aansluiting/Electrical connection
Branchement électrique/Elektrische anschluss

Vrije ruimte rondom toestel
Free space around appliance
Espace libre autour de l'appareil
Freier Raum rundum das Gerät

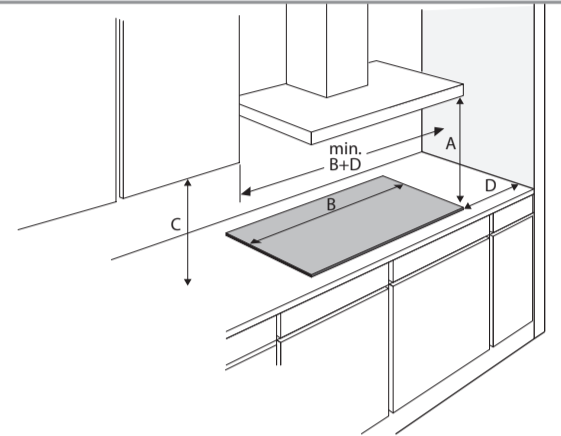

A (mm) C (mm) D (mm)
min. 650 min. 450 min. 40



Dit toestel moet altijd geaard zijn.
This appliance must be earthed.
Cet appareil doit être mis à la terre.
Dieses Gerät muß jederzeit geerdet sein.

De elektrische aansluiting moet voldoen aan de nationale en lokale voorschriften.
The electrical connection must comply with national and local regulations.
Le branchement électrique doit satisfaire aux prescriptions nationales et locales.
Der elektrische Anschluß muß den nationalen und kommunalen Vorschriften entsprechen.

Aansluitwaarden/Connected load/Charge connectée/Anschlussleistung

	L1 (W)	L2 (W)	L3 (W)	Total load (W)
IK4062M	3700	3700	0	7400
IK4062R	3700	3700	0	7400
IK4064SR	3680	0	0	3680
IK4064M	3600	3600	0	7200
IK4064R	3600	360	0	7200
IK4073M	3700	3700	0	7400
IK4083M	3700	3700	0	7400
IK4084M	3600	3600	0	7200
IK4084R	3600	3600	0	7200

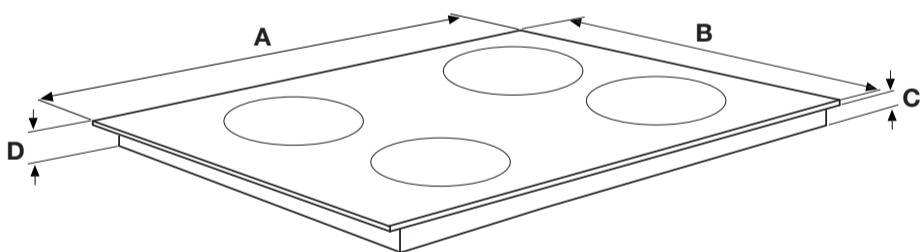

	A (mm)	B (mm)	C (mm)	D (mm)
IK4062M	600	522	50	54
IK4062R	598	520	50	54
IK4064M	600	522	50	54
IK4064SR/R	598	520	50	54
IK4073M	705	522	50	54
IK4083M	800	522	50	54
IK4084M	800	522	50	54
IK4084R	798	520	50	54

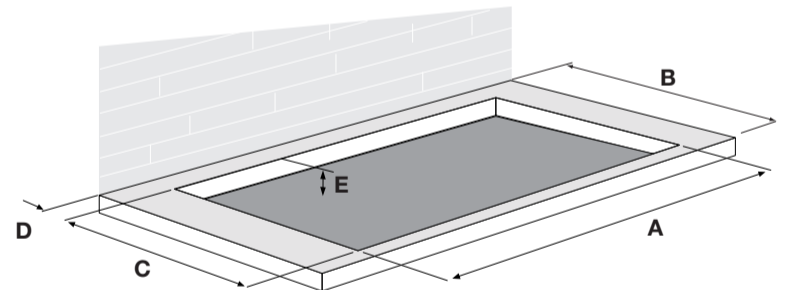

	A (mm)	B (mm)	C (mm)	D (>mm)	E (>mm)
IK4062/IK4064	560	600	490	40	70
IK4073	560	600	490	40	70
IK4083/IK4084	750	600	490	40	70

Afdichtband plaatsen/Placing sealing tape
Placement de la bande d'étanchéité/Abdichtband anbringen

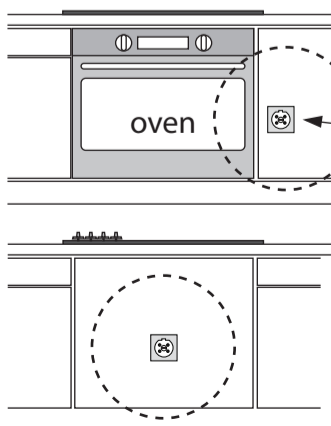

Bereikbaarheid!
Accessibility!
Accessibilité!
Zugänglichkeit!

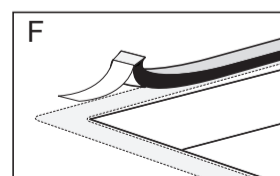

Aanrechtblad
Worktop
Plan de travail
Arbeitsplatte





Elektrische aansluiting/Electrical connection
Branchement électrique/Elektrische anschluss

2N 380-415V 50/60Hz - 2x 16A ⇔
 2 fase - 1 nul / 2 phases - 1 neutral
 2 Phasen - 1 Nullanschluss / 2 phases et 1 neutre

Aderdoorsnede
 Cross sectional area
 Fil diamètre
 Aderquerschnitt **4x1,5mm² (<2m)**

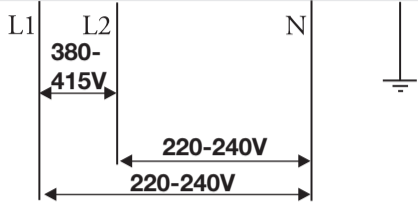

2-2N 220-240V 50Hz - 2x 16A ⇔
 2 fase - 2 nullen / 2 phases - 2 neutral
 2 Phasen - 2 Nullanschlüsse / 2 phases et 2 neutres

Aderdoorsnede
 Cross sectional area
 Fil diamètre
 Aderquerschnitt **5x1,5mm² (<2m)**

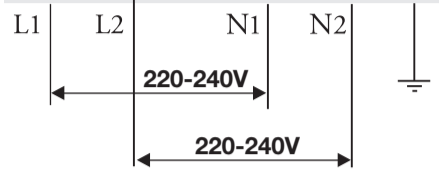

Only NL / Alleen NL



De 2 fasen van de kookgroep-automaat moeten door 1 aardlekschakelaar gevoed worden. Het is niet toegestaan om L1/N1 via een andere aardlekschakelaar te laten lopen dan L2/N2

1 1N 220-240V 50/60Hz - 1x 32A ⇔
 1 fase - 1 nul / 1 phase - 1 neutral
 1 Phase - 1 Nullanschluss / 1 phase et 1 neutre

Aderdoorsnede
 Cross sectional area
 Fil diamètre
 Aderquerschnitt **3x4 mm² (<2m)**



3N 380-415V 50/60Hz - 3x 16A ⇔
 3 fase - 1 nul / 3 phases - 1 neutral
 3 Phasen - 1 Nullanschluss / 3 phases et un neutre

Aderdoorsnede
 Cross sectional area
 Fil diamètre
 Aderquerschnitt **5x1,5 mm² (<2m)**

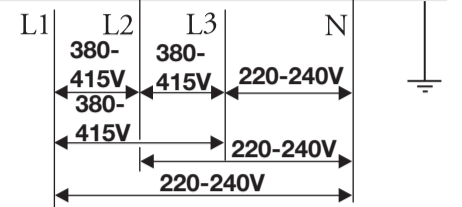

Raadpleeg de aansluitschema's op de achterzijde van het toestel/Maak de nodige doorverbindingen op het aansluitblok!
Consult the wiring diagrams on the back of the appliance/Make the required connections on the connecting block!
Consultez les schémas de raccordement situés derrière l'appareil/Effectuez les connexions nécessaires sur le bloc de raccordement !
Beachten Sie das Anschlussdiagramm auf der Rückseite des Geräts/Stellen Sie die erforderlichen Anschlussverbindungen am Anschlussblock her!

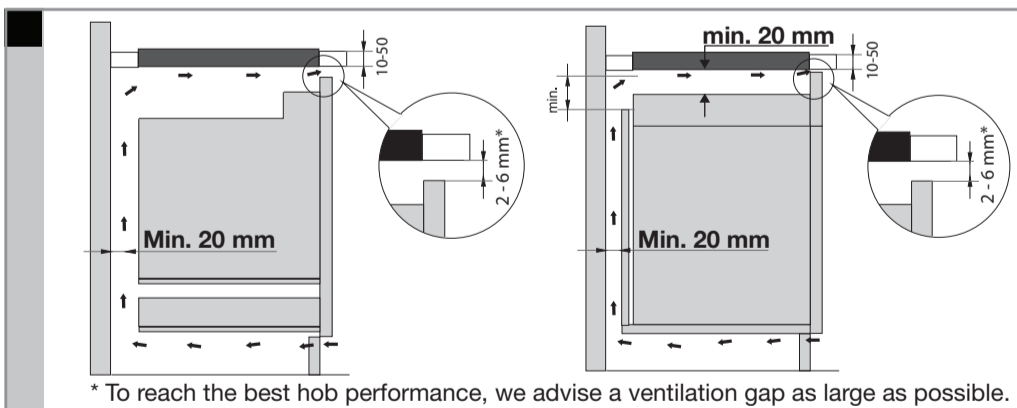
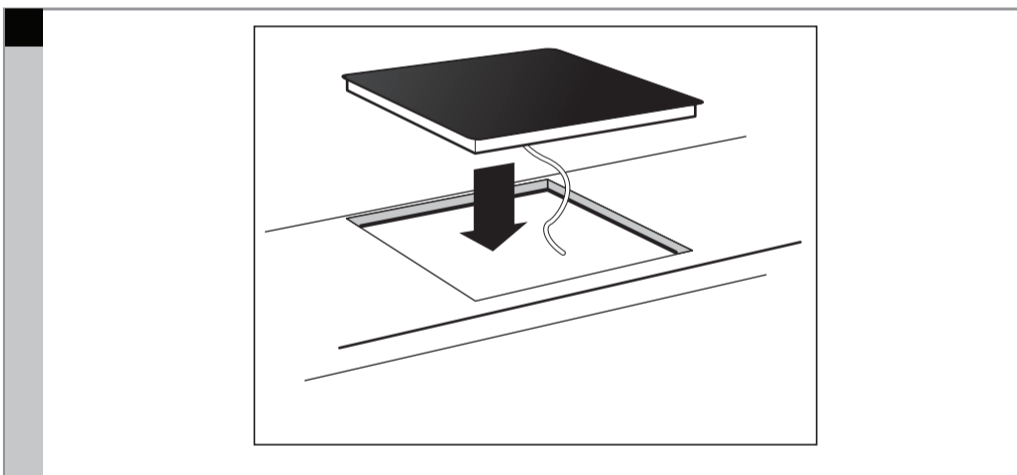
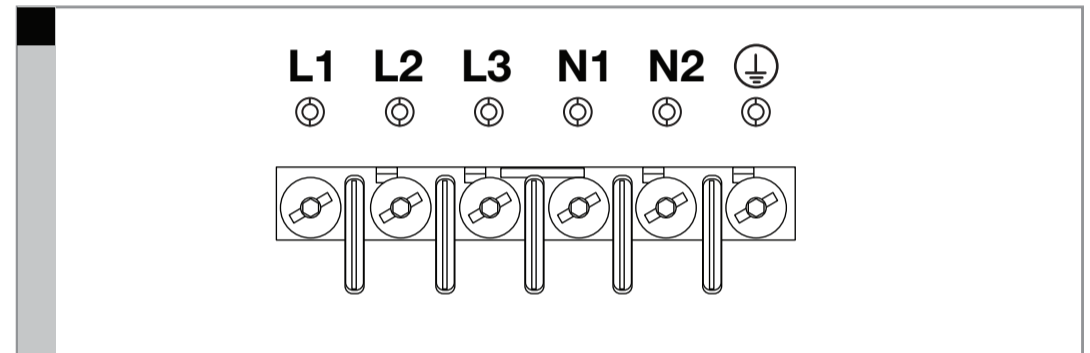
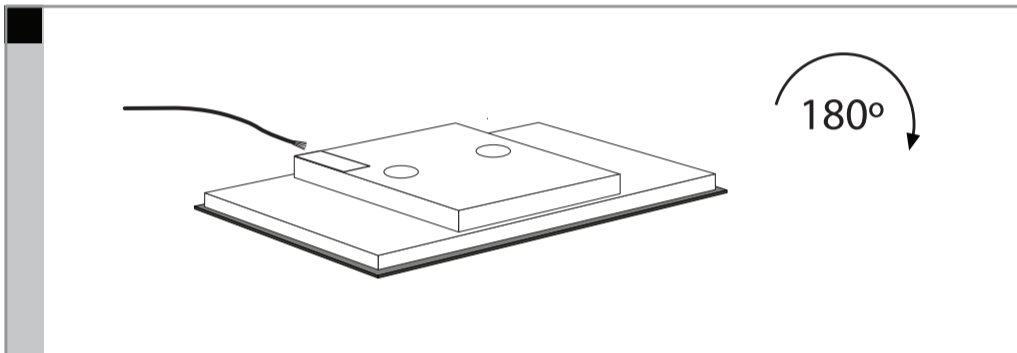

* To reach the best hob performance, we advise a ventilation gap as large as possible.

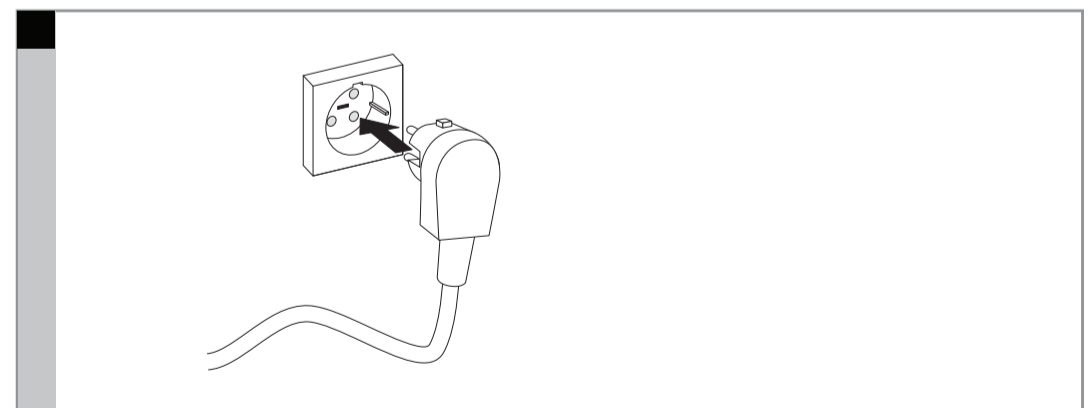

Op onze website kunt u de meest recente versie van het installatievoorschrift vinden.
 You can find the most recent version of the installation instructions on our website.
 Die neueste Version der Installationsanleitung finden Sie auf unserer Website.
 Vous pouvez trouver la version la plus récente des instructions d'installation sur notre site Web.

