

NL Installatievoorschrift
BE Inductiekookplaten

GB Installation instructions
 Induction hobs

DE Installationsanleitung
 Induktionskochfeld

FR Instructions d'installation
BE Plaque de cuisson induction



Dit toestel mag alleen door een erkend installateur worden aangesloten. Lees de veiligheidsvoorschriften. Dieses Gerät darf nur von einem anerkannten Installateur angeschlossen werden! Bitte lesen Sie die Sicherheitsbestimmungen. The fitting of the appliance should only be carried out by a registered Corgi qualified installer. Please read the safety regulations. Cet appareil ne peut être installé que par un technicien gazier agréé. Lisez les instructions de sécurité.

**Vorbereidungen voor montage/Vorbereitung der Montage/Preparations for installation
 Préparation avant installation**

Gebruikte pictogrammen/Verwendete Piktogramme/Pictograms used
 Pictogrammes utilisés

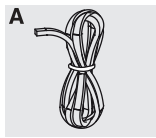

**Belangrijk om te weten/Wichtig zu wissen
 Important information/Important à savoir**



**Elektrische aansluiting/Elektrische ansluß
 Electrical connection/Branchement électrique**

**Vrije ruimte rondom toestel
 Freier Raum rundum das Gerät
 Free space around appliance
 Espace libre autour de l'appareil**

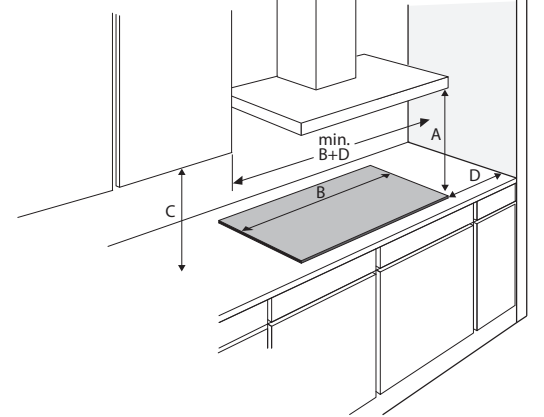

A (mm) C (mm) D (mm)
 min. 650 min. 450 min. 40



**Dit toestel moet altijd geaard zijn/Dieses Gerät muß jederzeit geerdet sein
 This appliance must be earthed/Cet appareil doit être mis à la terre**

De elektrische aansluiting moet voldoen aan de nationale en lokale voorschriften.
 Der elektrische Anschluß muß den nationalen und kommunalen Vorschriften entsprechen.
 The electrical connection must comply with national and local regulations.
 Le branchement électrique doit satisfaire aux prescriptions nationales et locales.

Aansluitwaarden/Anschlussleistung/Connected load/Charge connectée

	L1 (W)	L2 (W)	L3 (W)	Total load (W)
HI64..PP	3700			3700
HI64..E/Hi64..EV	3700	3700		7400
HI74..EV	3700	3700		7400

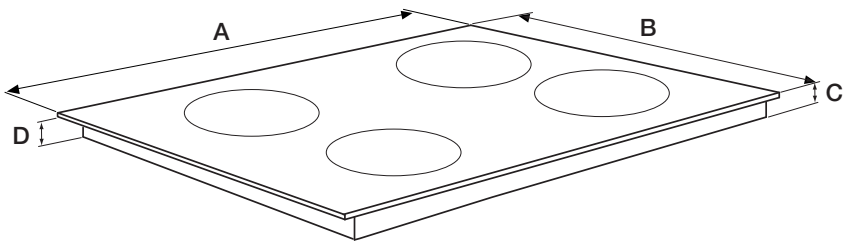

	A (mm)	B (mm)	C (mm)	D (mm)
HI64..	600	520	54	50
HI74..	700	520	54	50

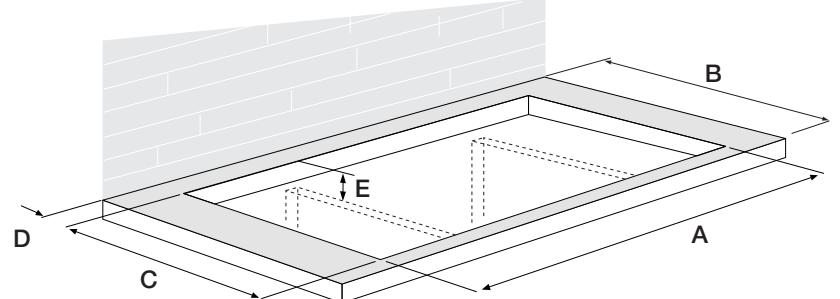

	A (mm)	B (mm)	C (mm)	D (>mm)	E (>mm)
HI64..	560	600	490	40	50
HI74..	560	600	490	40	50

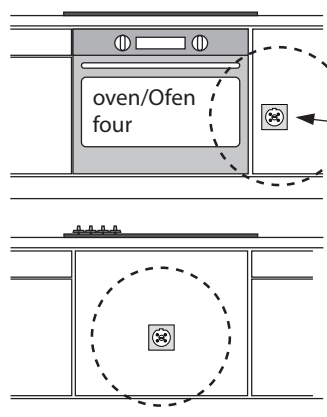

**Bereikbaarheid!
 Zugänglichkeit!
 Accessibility!
 Accessibilité!**

**Afdichtband plaatsen/Abdichtband anbringen/Placing sealing tape
Placement de la bande d'étanchéité**

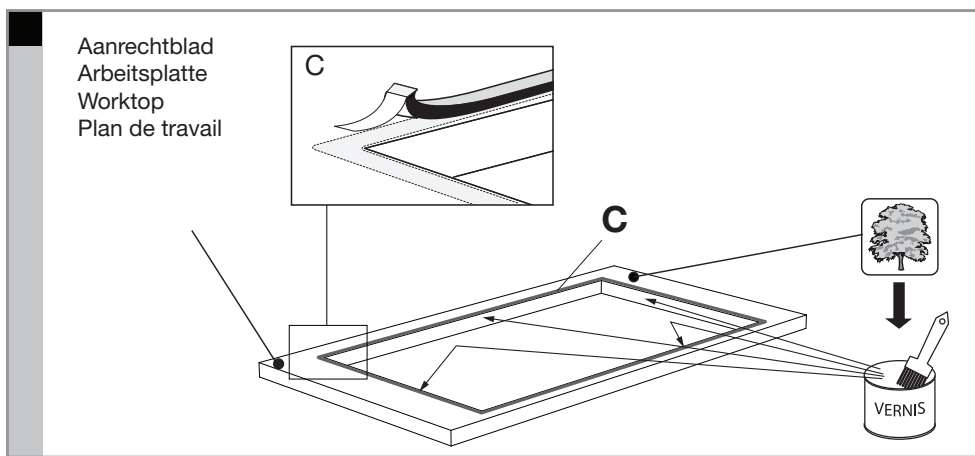

**Elektrische aansluiting/Elektrische anschluss/Electrical connection
Branchement électrique**

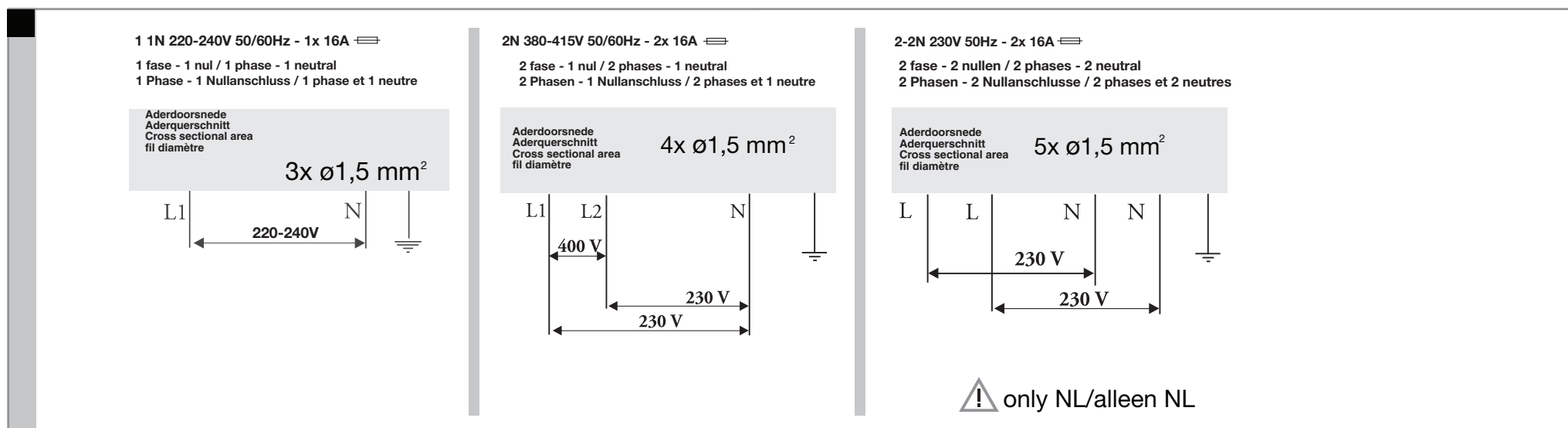

**Raadpleeg de aansluitschema's op de achterzijde van het toestel/Maak de nodige doorverbindingen op het aansluitblok!
Beachten Sie das Anschlussdiagramm auf der Rückseite des Geräts/Stellen Sie die erforderlichen Anschlussverbindungen am Anschlussblock her!
Consult the wiring diagrams on the back of the appliance/Make the required connections on the connecting block.
Consultez les schémas de raccordement situés derrière l'appareil/Effectuez les connexions nécessaires sur le bloc de raccordement !**

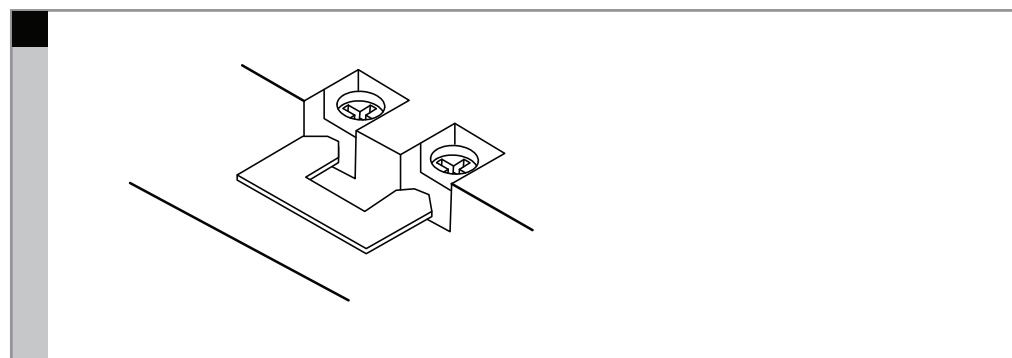
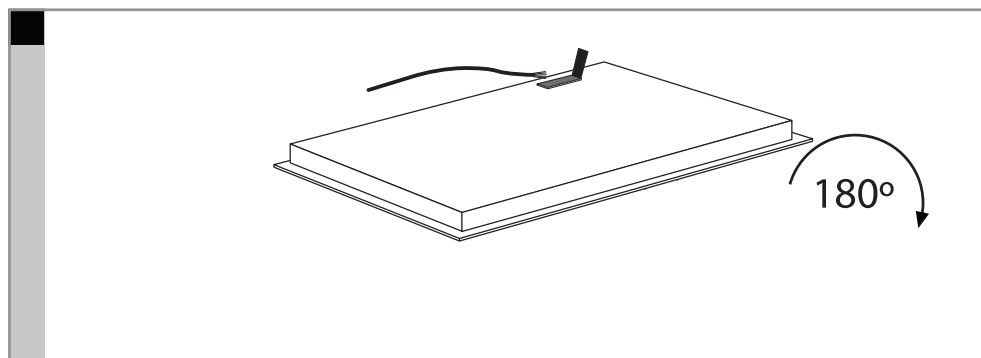

Beluchting/Belüftung/Ventilation

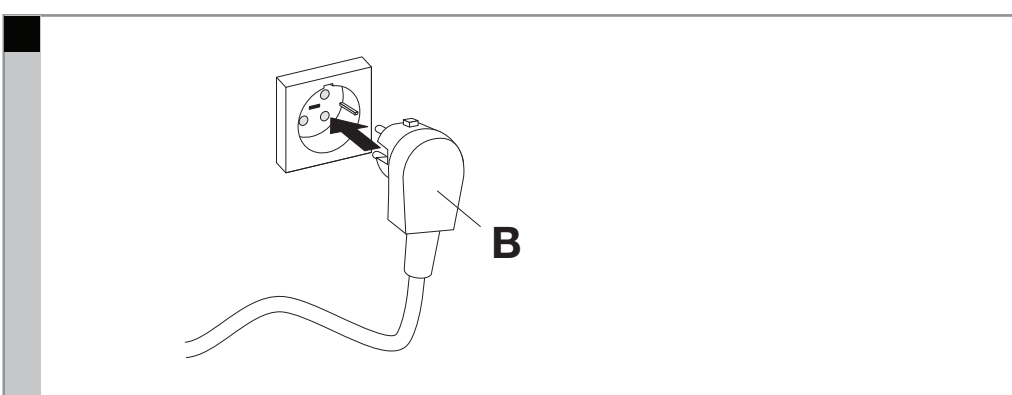
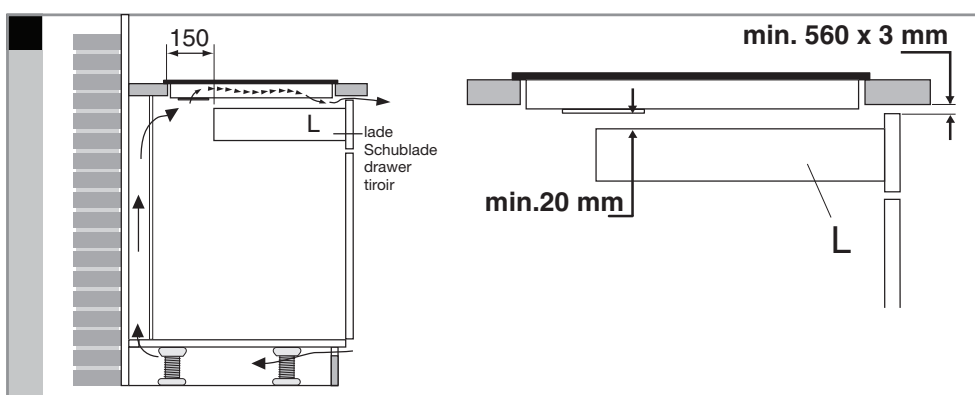
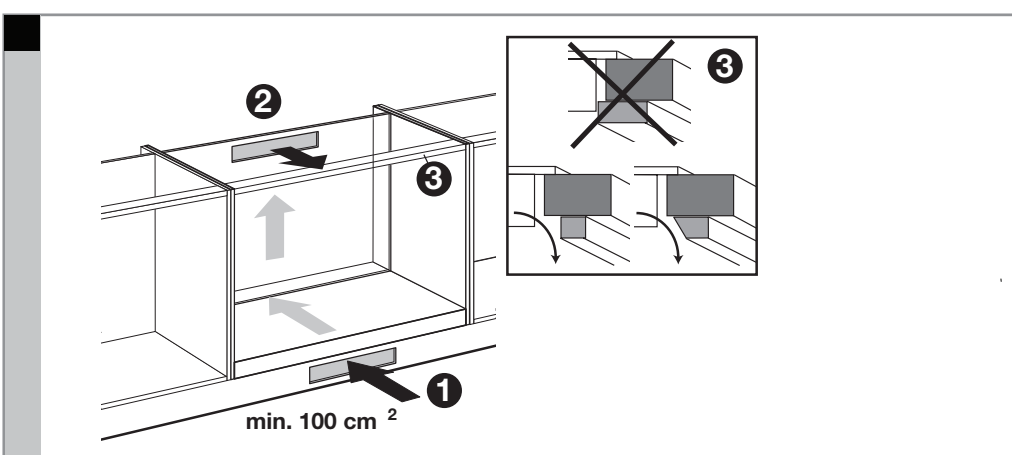
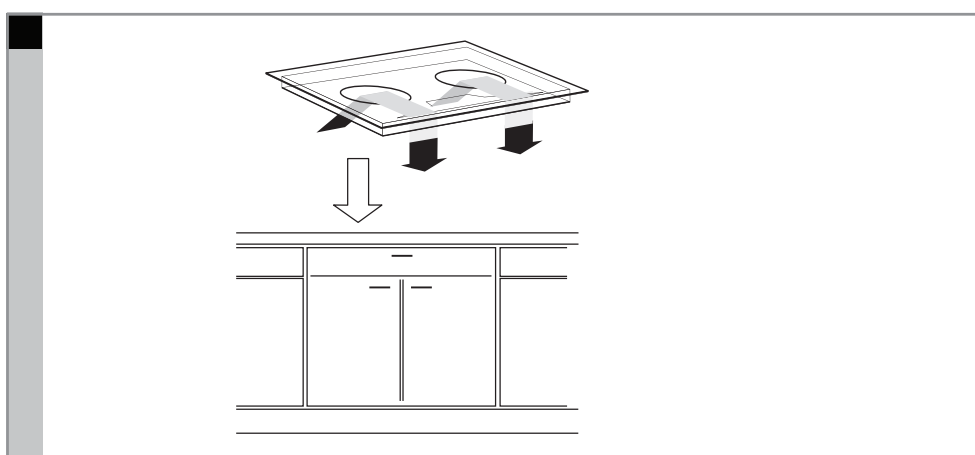

715231