



**Dit toestel mag alleen door een erkend installateur worden aangesloten. Lees de veiligheidsvoorschriften. Dieses Gerät darf nur von einem anerkannten Installateur angeschlossen werden! Bitte lesen Sie die Sicherheitsbestimmungen. The fitting of the appliance should only be carried out by a registered Corgi qualified installer. Please read the safety regulations. Cet appareil ne peut être installé que par un technicien gazier agréé. Lisez les instructions de sécurité.**

**Vorbereidingen voor montage/Vorbereitung der Montage/Preparations for installation  
Préparation avant installation**

**Gebruikte pictogrammen/Verwendete Piktogramme/Pictograms used  
Pictogrammes utilisés**



**Belangrijk om te weten/Wichtig zu wissen  
Important information/Important à savoir**



**Elektrische aansluiting/Elektrische ansluß  
Electrical connection/Branchement électrique**

**Vrije ruimte rondom toestel  
Freier Raum rundum das Gerät  
Free space around appliance  
Espace libre autour de l'appareil**

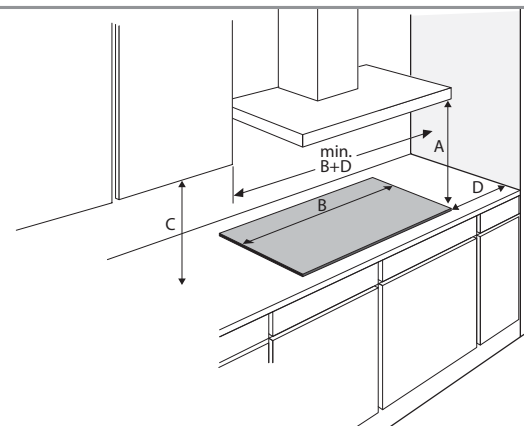

A (mm) C (mm) D (mm)  
min. 650 min. 450 min. 40



**Dit toestel moet altijd geaard zijn/Dieses Gerät muß jederzeit geerdet sein  
This appliance must be earthed/Cet appareil doit être mis à la terre**

De elektrische aansluiting moet voldoen aan de nationale en lokale voorschriften.  
Der elektrische Anschluß muß den nationalen und kommunalen Vorschriften entsprechen.  
The electrical connection must comply with national and local regulations.  
Le branchement électrique doit satisfaire aux prescriptions nationales et locales.

**Aansluitwaarden/Anschlussleistung/Connected load/Charge connectée**

	L1 (W)	L2 (W)	L3 (W)	Total load (W)
HI32	3700			3700
HI62..E/HI72..E	3700	3700		7100
HI62/HI72/HI82/HI12/HI84	3700	3700		7400
HI95...T	3700	3700		7400
HI92/HI95	3700	3700	3700	11100

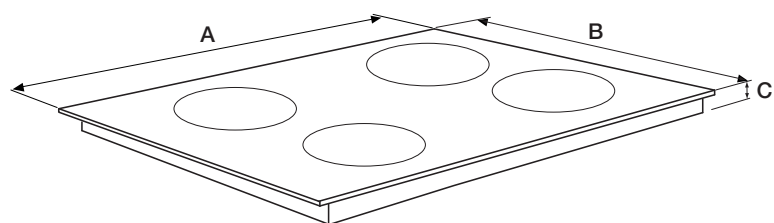

	A (mm)	B (mm)	C (mm)		A (mm)	B (mm)	C (mm)
HI32	330	522	43	HI72..E	700	510	56
HI62	644	522	43	HI82/HI84	804	522	43
HI62...I	640	510	50	HI82...I	800	510	50
HI62..E	600	510	56	HI92/HI95	904	522	43
HI72	774	522	43	HI92...I	900	510	50
HI72...I	770	510	50	HI12	1114	412	43

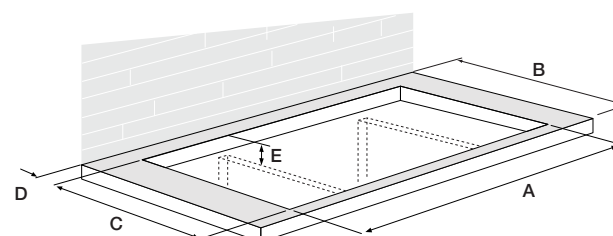

	A (mm)	B (mm)	C (mm)	D (>mm)	E (>mm)
HI32	290	600	490	40	--
HI62	560	600	490	40	--
HI72..E	560	600	490	40	--
HI72	750	600	490	40	46
HI82/HI84	780	600	490	40	46
HI92/HI95	860	600	490	40	46
HI12	1070	600	385	40	46

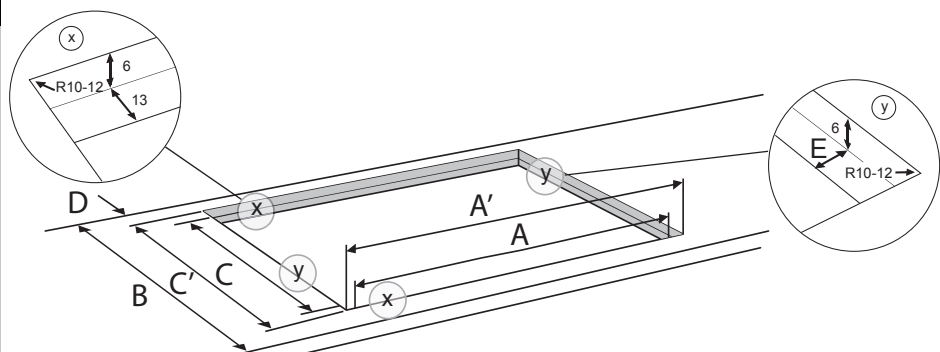

	A' (mm)	A (mm)	C' (mm)	C (mm)	D (>mm)	E (mm)
HI62...I	646 <sup>-1</sup>	560	516 <sup>-1</sup>	490	40	43
HI72...I	776 <sup>-1</sup>	750	516 <sup>-1</sup>	490	40	13
HI82...I	806 <sup>-1</sup>	780	516 <sup>-1</sup>	490	40	13
HI92...I	906 <sup>-1</sup>	860	516 <sup>-1</sup>	490	40	23

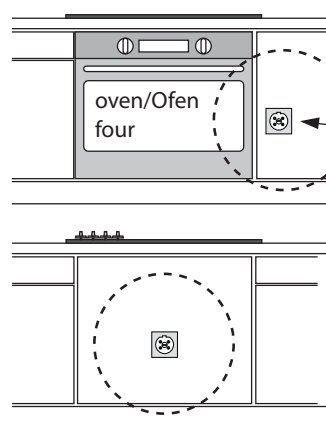

**Bereikbaarheid!  
Zugänglichkeit!  
Accessibility!  
Accessibilité!**

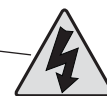

**Afdichtband plaatsen/Abdichtband anbringen/Placing sealing tape**  
**Placement de la bande d'étanchéité**

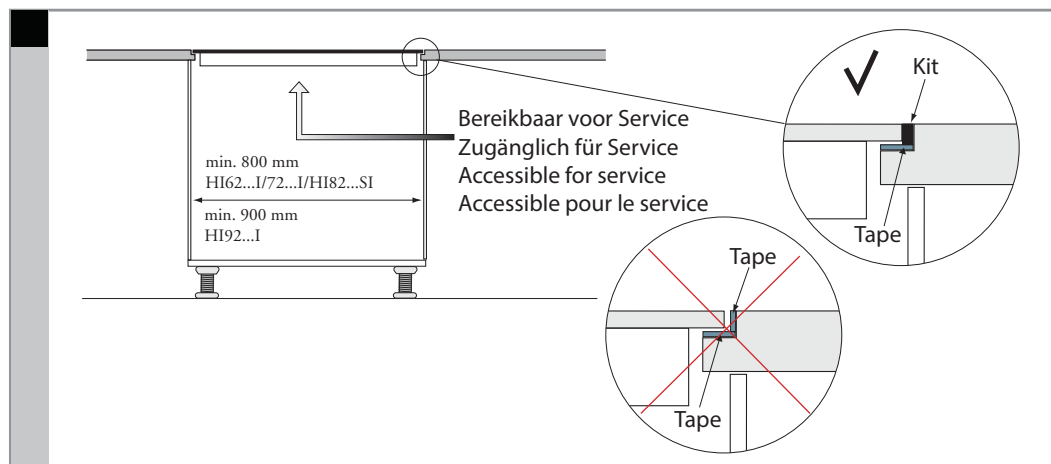
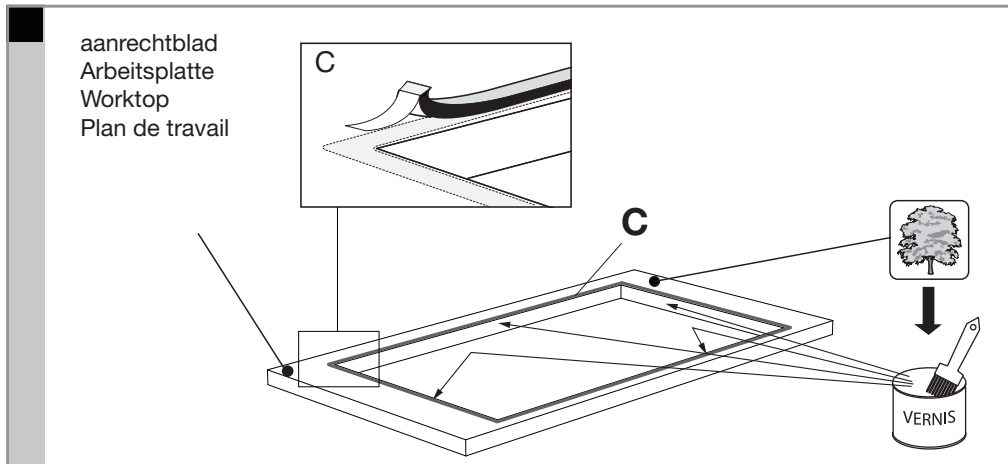

**Elektrische aansluiting/Elektrische an-schluß/Electrical connection**  
**Branchement électrique**

<p>3N 380-415V 50/60Hz - 3x 16A ⇔          3 fase - 1 nul / 3 phases - 1 neutral/          3 Phasen- 1 Nullanschluss / 3 phases et un neutre</p>	<p>2N 380-415V 50/60Hz - 2x 16A ⇔          2 fase - 1 nul / 2 phases - 1 neutral          2 Phasen - 1 Nullanschluss / 2 phases et 1 neutre</p>	<p>1N 220-240V 50/60Hz - 1x 32A ⇔ 1x48A (HI92)          1 fase - 1 nul / 1 phase - 1 neutral          1 Phase - 1 Nullanschluss / 1 phase et 1 neutre</p>	<p>2-2N 230V 50Hz - 2x 16A ⇔          2 fase - 2 nullen / 2 phases - 2 neutral          2 Phasen - 2 Nullanschlusse / 2 phases et 2 neutres</p>
<p>Aderdoorsnede Aderquerschnitt Cross sectional area fil diamètre</p> <p><b>5x1,5 mm<sup>2</sup></b></p>	<p>Aderdoorsnede Aderquerschnitt Cross sectional area fil diamètre</p> <p><b>4x1,5 mm<sup>2</sup></b></p>	<p>Aderdoorsnede Aderquerschnitt Cross sectional area fil diamètre</p> <p><b>3x4 mm<sup>2</sup></b>  <b>3x10 mm<sup>2</sup> (HI95)</b></p>	<p>Aderdoorsnede Aderquerschnitt Cross sectional area fil diamètre</p> <p><b>5x1,5 mm<sup>2</sup></b></p>
<p>⚠ only NL/alleen NL</p>			

**Raadpleeg de aansluitschema's op de achterzijde van het toestel/Maak de nodige doorverbindingen op het aansluitblok!**  
**Beachten Sie das Anschlussdiagramm auf der Rückseite des Geräts/Stellen Sie die erforderlichen Anschlussverbindungen am Anschlussblock her!**  
**Consult the wiring diagrams on the back of the appliance/Make the required connections on the connecting block.**  
**Consultez les schémas de raccordement situés derrière l'appareil/Effectuez les connexions nécessaires sur le bloc de raccordement !**

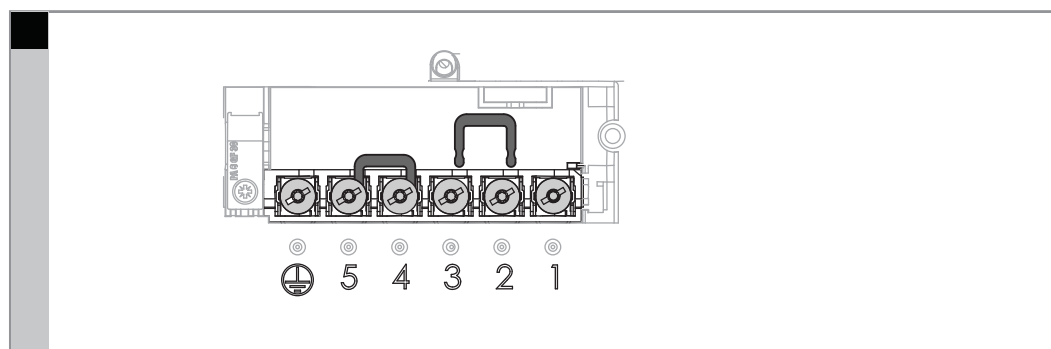
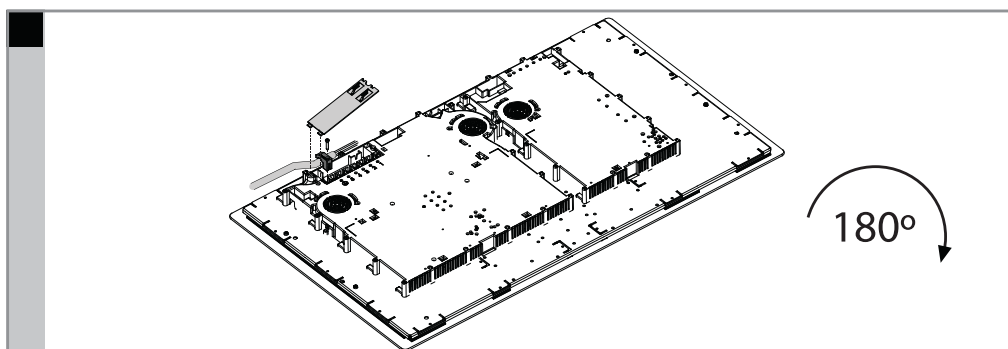

**Beluchting/Belüftung/Ventilation**

