

**NL** Installatievoorschrift  
Inductiekookplaten

**GB** Installation instructions  
Induction hobs

**DE** Installationsanleitung  
Induktionskochfeld

**FR** Instructions d'installation  
**BE** Plaque de cuisson induction



Dit toestel mag alleen door een erkend installateur worden aangesloten. Lees de veiligheidsvoorschriften.  
The fitting of the appliance should only be carried out by a registered and qualified installer. Please read the safety regulations.  
Cet appareil ne peut être installé que par un technicien gazier agréé. Lisez les instructions de sécurité.  
Dieses Gerät darf nur von einem anerkannten Installateur angeschlossen werden! Bitte lesen Sie die Sicherheitsbestimmungen.

**Vorbereidingen voor montage/Preparations for installation  
Préparation avant installation/Vorbereitung der Montage**

Gebuchte pictogrammen/Pictograms used  
Pictogrammes utilisés/Verwendete Piktogramme

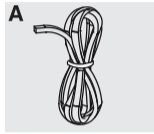

Belangrijk om te weten/Important information  
Important à savoir/Wichtig zu wissen



Elektrische aansluiting/Electrical connection  
Branchement électrique/Elektrische anschluss

Vrije ruimte rondom toestel  
Free space around appliance  
Espace libre autour de l'appareil  
Freier Raum rundum das Gerät

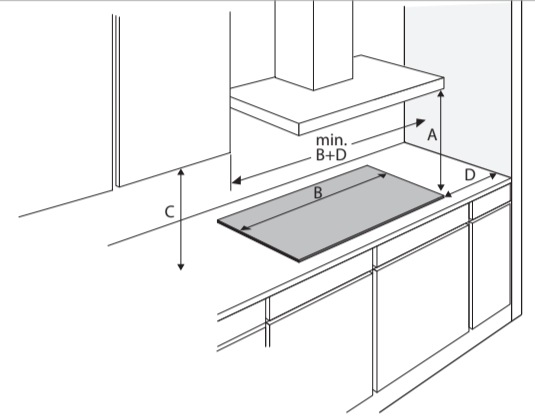

A (mm) C (mm) D (mm)  
min. 650 min. 450 min. 40



Dit toestel moet altijd geaard zijn.  
This appliance must be earthed.  
Cet appareil doit être mis à la terre.  
Dieses Gerät muß jederzeit geerdet sein.

De elektrische aansluiting moet voldoen aan de nationale en lokale voorschriften.  
The electrical connection must comply with national and local regulations.  
Le branchement électrique doit satisfaire aux prescriptions nationales et locales.  
Der elektrische Anschluß muß den nationalen und kommunalen Vorschriften entsprechen.

**Aansluitwaarden/Connected load/Charge connectée/Anschlussleistung**

	L1 (W)	L2 (W)	L3 (W)	Total load (W)
CK1064R/CK1064KR	3400	3000		6400
CK3084R	3500	3600		7100
CK3095R	3600	3600		7200

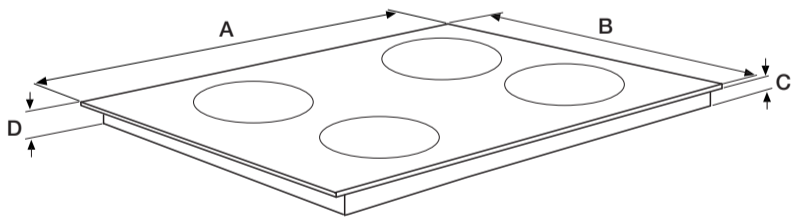

	A (mm)	B (mm)	C (mm)	D (mm)
CK1064R	595	520	55	60
CK1064KR	595	520	58	63
CK3084R	795	520	55	60
CK3095R	900	520	55	60

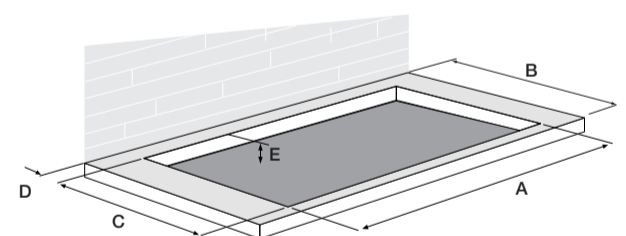

	A (mm)	B (mm)	C (mm)	D (>mm)	E (>mm)
CK1064R/CK1064KR	560	600	490	40	80
CK3084R	750	600	490	40	80
CK3095R	880	600	490	40	80

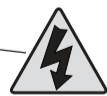
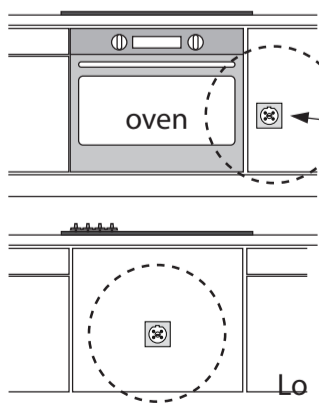

Bereikbaarheid!  
Accessibility!  
Accessibilité!  
Zugänglichkeit!

**Afdichtband plaatsen/Placing sealing tape**  
**Placement de la bande d'étanchéité/Abdichtband anbringen**

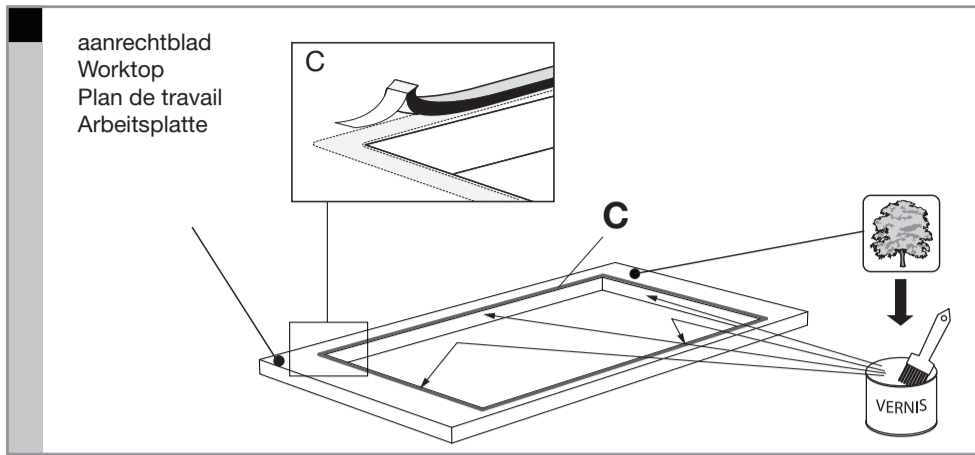

**Elektrische aansluiting/Electrical connection**  
**Branchement électrique/Elektrische anschluss**

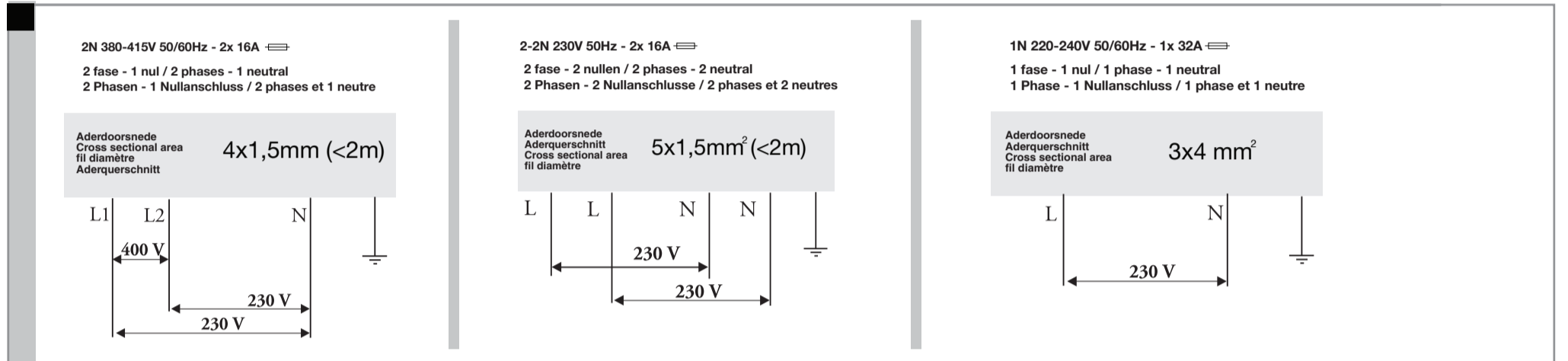

**Raadpleeg de aansluitschema's op de achterzijde van het toestel/Maak de nodige doorverbindingen op het aansluitblok!**  
**Consult the wiring diagrams on the back of the appliance/Make the required connections on the connecting block.**  
**Consultez les schémas de raccordement situés derrière l'appareil/Effectuez les connexions nécessaires sur le bloc de raccordement !**  
**Beachten Sie das Anschlussdiagramm auf der Rückseite des Geräts/Stellen Sie die erforderlichen Anschlussverbindungen am Anschlussblock her!**

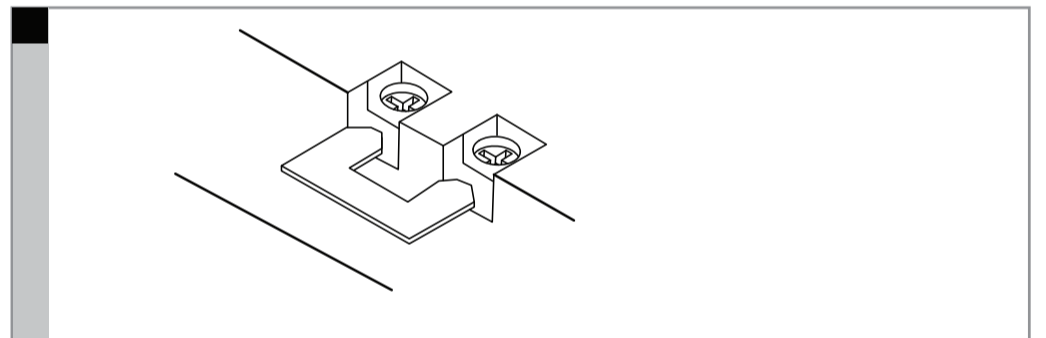
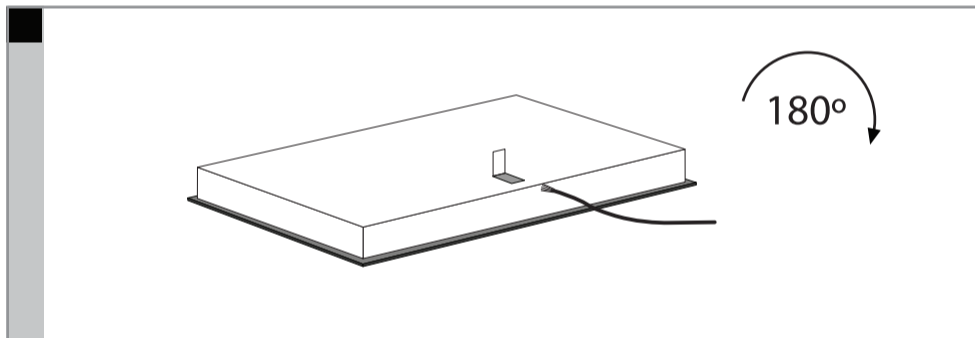

**Beluchting/Ventilation/Belüftung/**

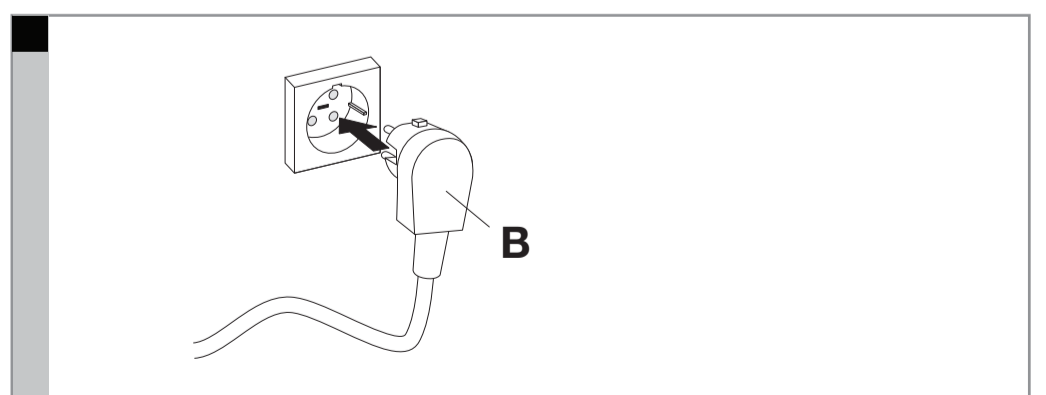
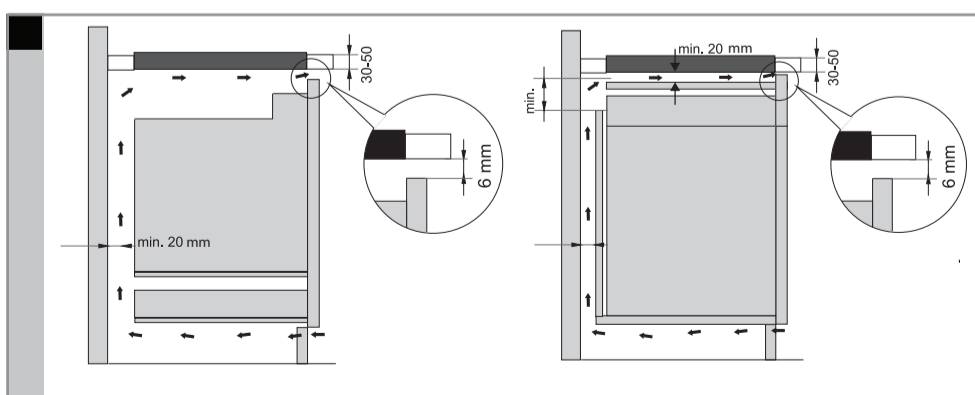
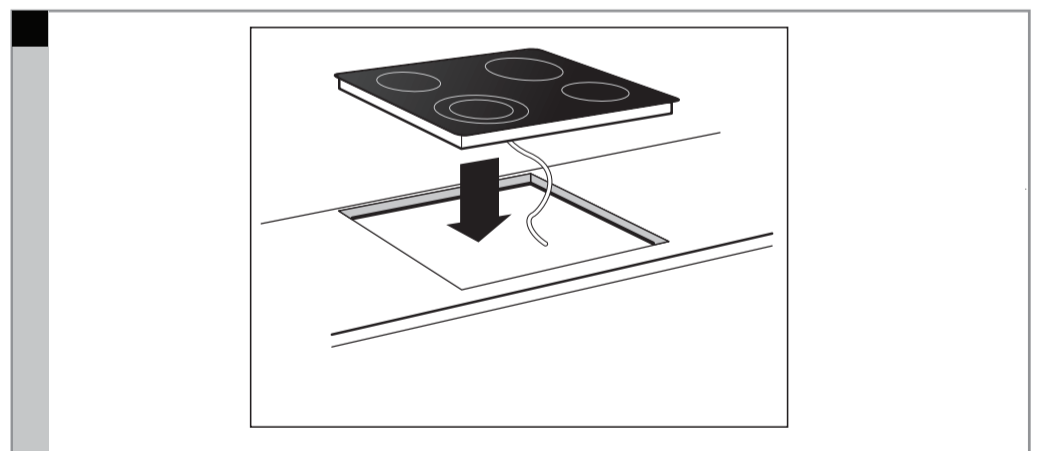
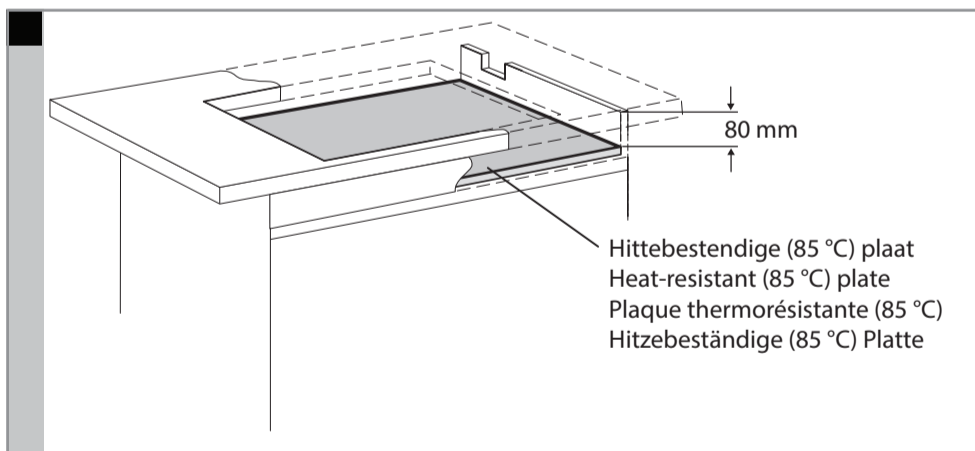

718250